

RELY ON EXCELLENCE

SH(V)

Mechanical seals | Mechanical seals for pumps | Engineered seals



Features

- Cartridge design
- Single seal
- Balanced
- Multiple springs
- Stationary spring loaded unit
- Shrink-fitted seal face

Advantages

- Deformation-optimized seal for high pressures and high sliding velocities (static up to 500 bar (7,250 PSI) and dynamic up to 150 bar (2,175 PSI))
- Economical due to standardized inner components
- High flexibility due to adaptation of the connection parts to the pump seal chamber
- Insensitive to shaft deflections due to stationary design
- Pre-assembled unit for quick and easy installation
- Suitable for use in compliance with API 682, type ES
- Version with loose-fitted seal face available, for extreme applications
- Only small number of components

Operating range

Shaft diameter:
 $d1^* = 40 \dots 250 \text{ mm} (1.57'' \dots 9.84'')$
 Pressure: $p1 = 150 \text{ bar} (2,175 \text{ PSI})$
 Temperature: $t = +200 \text{ }^\circ\text{C} (+394 \text{ }^\circ\text{F})$,
 Sliding velocity: $v_g = 60 \text{ m/s} (197 \text{ ft/s})$
 Axial movement: $\pm 3 \text{ mm}$

* Other sizes on request

Materials

Seal face:

SiC-C-Si silicon impregnated carbon (Q3),
 Carbon graphite antimony impregnated (A)
 Seat: Silicon carbide (Q)

Secondary seals:

FKM (V), EPDM (E), FFKM (K)

Springs: Hastelloy® C-4 (M)

Metal parts: CrNiMo steel (G), Duplex (G1),
 Super Duplex (G4), Titanium (T2), Hastelloy®
 C-4 (M)

Standards and approvals

- API 682 / ISO 21049

Recommended applications

- Oil and gas industry
- Refining technology
- Petrochemical industry
- Chemical industry
- Power plant technology
- Pulp and paper industry
- Water and waste water technology
- Hot water
- Sour water
- Caustic soda
- Amines
- Crystallizing media
- Crude oil
- Process water
- Crude oil feed pumps
- Injection pumps
- Multiphase pumps

Recommended piping plans

[API Plan 11](#)

[API Plan 13](#)

[API Plan 31](#)

[API Plan 32](#)

[API Plan 41](#)

[API Plan 61](#)

RELY ON EXCELLENCE

API Plan 62

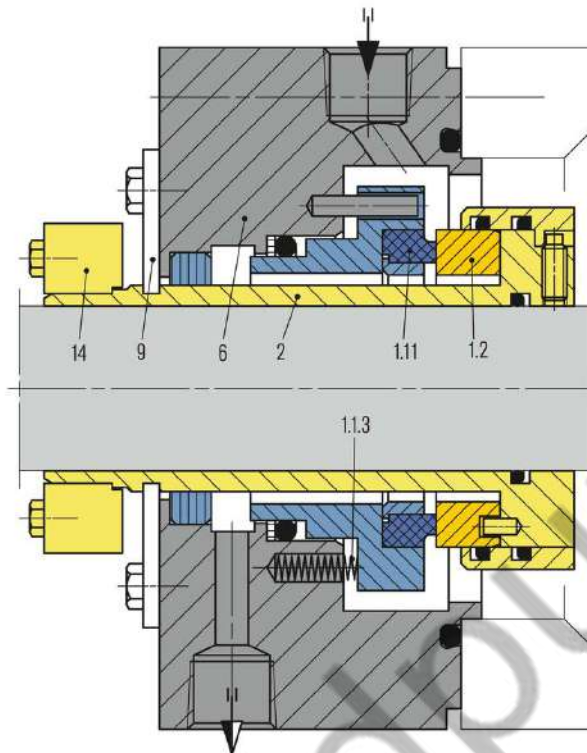

Item Description

- 1.1.1 Seal face
- 1.1.3 Spring
- 1.2 Seat
- 2 Shaft sleeve
- 6 Cover
- 9 Assembly fixture
- 14 Shrink disk

Product variants

SH(V) Same design as SH(V) but with loosely inserted seal face for extreme applications.
 Pressure: $p_1 = 200 \text{ bar (2,900 PSI)}$