

RELY ON EXCELLENCE

SAF(V) / SAP(V)

Mechanical seals | Mechanical seals for pumps | Engineered seals



Features

- Cartridge design
- Single seal
- Balanced
- Dependent on direction of rotation
- Integrated pumping device
- Stationary spring loaded unit
- Inserted seal face
- Rotating carbon seat

Advantages

- Deformation-optimized seal for high sliding velocities and medium pressures
- Economical due to standardized inner components
- High flexibility due to adaptation of the connection parts to the pump seal chamber
- Optimum heat dissipation due to integrated pumping device and optimized seat / seal face design
- Insensitive to shaft deflections due to stationary design
- Pre-assembled unit for quick and easy installation
- Only small number of components

Operating range

Shaft diameter:
 $d1^* = 120 \dots 250 \text{ mm} (4.72" \dots 9.84")$
 Pressure: $p1 = 50 \text{ bar} (725 \text{ PSI})$
 Temperature: $t = +300 \text{ }^\circ\text{C} (+572 \text{ }^\circ\text{F})$
 Sliding velocity: $vg = 65 \text{ m/s} (213 \text{ ft/s})$
 Axial movement: $\pm 3 \text{ mm}$

* Other sizes on request

Materials

Seal face: Silicon carbide (Q), SiC-C-Si Silicon impregnated carbon (Q3)
 Seat: Carbon graphite resin impregnated (B), SiC-C-Si Silicon impregnated carbon (Q3)
 Secondary seals: EPDM (E), FFKM (K)
 Springs: CrNiMo steel (G)
 Metal parts: CrNiMo steel (G)

Recommended applications

- Power plant technology
- Oil and gas industry
- Refining technology
- Petrochemical industry
- Chemical industry
- Boiler feed water with low conductivity
- Boiler feed pumps

Recommended piping plans

API Plan 02 + API Plan 23 (with jacket cooling)

RELY ON EXCELLENCE

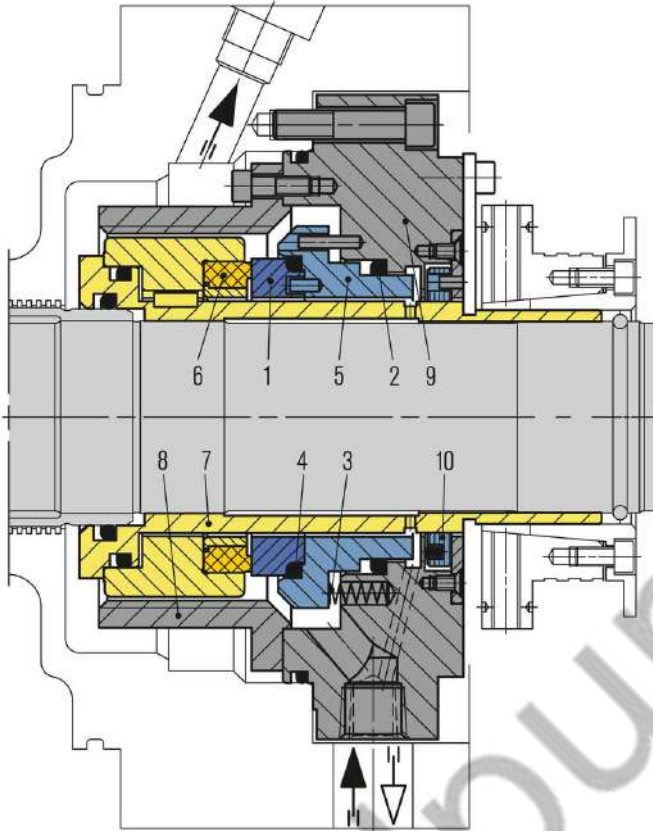

Item Description

- | | |
|----|----------------|
| 1 | Seal face |
| 2 | O-Ring |
| 3 | Spring |
| 4 | O-Ring |
| 5 | Seat collar |
| 6 | Seat |
| 7 | Shaft sleeve |
| 8 | Pumping sleeve |
| 9 | Cover |
| 10 | Throttle ring |