

RELY ON EXCELLENCE

## EH700

Mechanical seals | Mechanical seals for pumps | Elastomer bellows seals



### Features

- Single seal
- Stationary spring-loaded unit enables operation in high-range loads area
- Balanced
- In-house manufactured carbon seal faces

### Advantages

The seal for stationary applications. The EH700 is based on a unique stationary spring loaded unit that enables the seal to operate under high speed and high pressure. An additional advantage of the seal is the balanced design, which ensures good sealing performance in high-load conditions.

### Operating range

Shaft diameter:  $d_1 = 15 \dots 35 \text{ mm}$   
Pressure:  $p_1 = 15 \text{ bar (218 PSI)}$ , vacuum up to 0.1 bar  
Temperature:  
 $t = -20 \text{ °C} \dots +100 \text{ °C} (-4 \text{ °F} \dots +212 \text{ °F})$   
Sliding velocity:  $v_g = 10 \text{ m/s (33 ft/s)}$   
Axial movement:  $\pm 1.0 \text{ mm}$

### Materials

Seal face: Carbon graphite resin impregnated (B)  
Seat: Aluminium oxide (V, V1), Silicon carbide (Q1, Q2)  
Secondary seals: NBR (P), FKM (V)  
Metal parts: CrNi steel (F)

### Recommended applications

- Water and waste water technology
- Food and beverage industry
- Water and waste water
- Glycols
- Industrial pumps
- Engine pumps
- Skyscraper water supply pumps

RELY ON EXCELLENCE

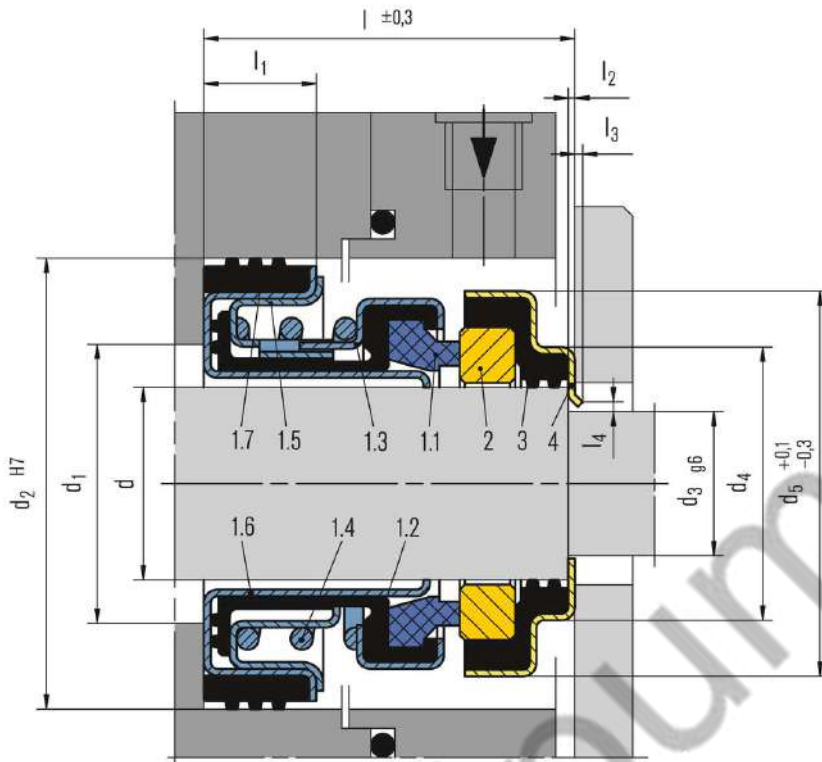

### Item Description

- 1.1 Seal face
- 1.2 Bellows
- 1.3 Spring collar
- 1.4 Spring
- 1.5 Spring holder
- 1.6 Cartridge
- 1.7 Seat ring
- 2 Seat
- 3 Corner sleeve
- 4 Case

## Dimensions

d	d <sub>1</sub>	d <sub>2</sub>	d <sub>3</sub>	d <sub>4</sub>	d <sub>5</sub>	l	l <sub>1</sub>	l <sub>2</sub>	l <sub>3</sub>	l <sub>4</sub>	l <sub>5</sub>
15	22	41	12	22	34	29.5	9.5	0.6	-	-	-
20	30	45	12	27.2	45	31	11	0.6	2	1	3.4
25	35	52	22	33.6	52	37	11.5	0.8	2.5	1	4.2
35	45	66	32	43.6	66	41.6	12.5	0.8	4	1	5.2

Dimensions in Millimeter