

RELY ON EXCELLENCE

MFL85N

Mechanical seals | Mechanical seals for pumps | Metal bellows seals



Features

- For unstepped shafts
- Single seal
- Balanced
- Independent of direction of rotation
- Metal bellows rotating

Advantages

- For extreme temperature ranges
- No dynamically loaded O-Ring
- Self cleaning effect
- Short installation length possible
- Pumping screw for highly viscous media available (dependent on direction of rotation).

Operating range

Shaft diameter:
 $d_1 = 16 \dots 100 \text{ mm (0.63" \dots 4")}$
Externally pressurized:
 $p_1 = \dots 25 \text{ bar (363 PSI)}$
Internally pressurized:
 $p_1 < 120 \text{ °C (248 °F) } 10 \text{ bar (145 PSI)}$
 $p_1 < 220 \text{ °C (428 °F) } 5 \text{ bar (72 PSI)}$
Temperature: $t = -40 \text{ °C} \dots +220 \text{ °C}$
 $(-40 \text{ °F} \dots 428) \text{ °F}$,
Stationary seat lock necessary.
Sliding velocity: $v_g = 20 \text{ m/s (66 ft/s)}$

Materials

Seal face: Carbon graphite antimony impregnated (A), Silicon carbide (Q12)
Seat: Silicon carbide (Q1)
Bellows: Inconel® 718 hardened (M6), Hastelloy® C-276 (M5)
Metal parts: CrNiMo steel (G), Duplex (G1), Hastelloy® C-4 (M)

Standards and approvals

- EN 12756

Recommended applications

- Process industry
- Oil and gas industry
- Refining technology
- Petrochemical industry
- Chemical industry
- Hot media
- Cold media
- Highly viscous media
- Pumps
- Special rotating equipment

RELY ON EXCELLENCE

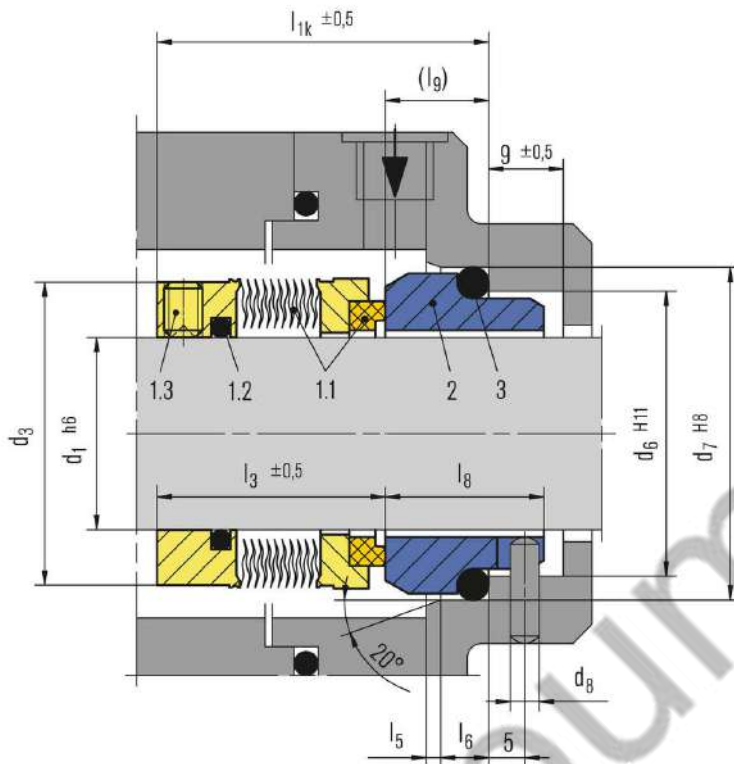

Item	Part no.	Description
DIN 24250		
1.1	472/481	Seal face with bellows unit
1.2	412.1	O-Ring
1.3	904	Set screw
2	475	Seat (G9)
3	412.2	O-Ring

Seat alternatives

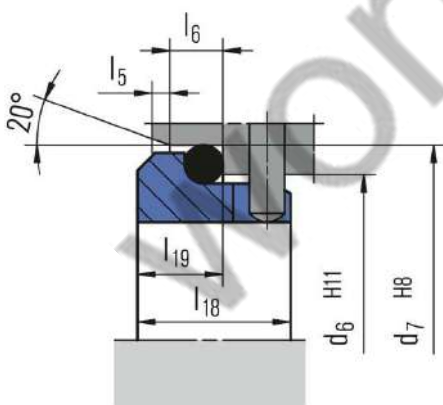

G16
(l_{1k} shorter than specified by EN 12756)

RELY ON EXCELLENCE

Product variants

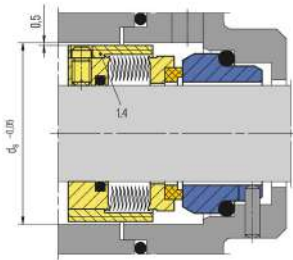

MFL85F

Dimensions, items and description as for MFL85N, but with pumping screw (item no. 1.4). Dependent on direction of rotation. The pumping screw can be retrofitted.

MFL90N

Shaft diameter:
 $d_1 = 20 \dots 100 \text{ mm} (0.79 \dots 4\text{'})$
Internally pressurized:
 $p_1 = \dots 16 \text{ bar} (232 \text{ PSI})$,
stationary seat lock necessary.
Externally pressurized:
 $p_1 = 10 \text{ bar} (145 \text{ PSI})$
Temperature:
 $t = -40 \text{ °C} \dots +220 \text{ °C} (-40 \text{ °F} \dots +428 \text{ °F})$
Sliding velocity: $vg = 20 \text{ m/s} (66 \text{ ft/s})$

MFL85P / MFL90P

Version with pumping ring. Dependent on direction of rotation. Can be retrofitted.

RELY ON EXCELLENCE

Dimensions

d ₁	d ₃	d ₆	d ₇	d ₈	d _s	l _{1K}	l ₃	l ₅	l ₆	l ₈	l ₉	l ₁₈	l ₁₉	b	s
16	30.0	23	27	3	38	42.5*)	32.5	1.5	4	17.5	10.0	-	-	1.6	9.0
18	32.0	27	33	3	39	42.0	30.5	2.0	5	14.0	11.5	15.0	7.0	1.6	10.0
20	33.5	29	35	3	41	42.0	30.5	2.0	5	14.0	11.5	15.0	7.0	1.6	10.0
22	36.5	31	37	3	44	37.5	30.5	2.0	5	14.0	11.5	15.0	7.0	1.6	10.0
24	39.0	33	39	3	47	40.0	28.5	2.0	5	19.5	11.5	15.0	7.0	1.6	8.2
25	39.6	34	40	3	48	40.0	28.5	2.0	5	19.5	11.5	15.0	7.0	1.6	8.5
28	42.8	37	43	3	51	42.5	31.0	2.0	5	19.5	11.5	15.0	7.0	1.6	9.0
30	45.0	39	45	3	53	42.5	31.0	2.0	5	19.5	11.5	15.0	7.0	1.6	8.5
32	46.0	42	48	3	55	42.5	31.0	2.0	5	19.5	11.5	15.0	7.0	1.6	9.2
33	48.0	42	48	3	56	42.5	31.0	2.0	5	19.5	11.5	15.0	7.0	1.6	9.2
35	49.2	44	50	3	58	42.5	31.0	2.0	5	19.5	11.5	15.0	7.0	1.6	9.5
38	52.3	49	56	4	61	45.0	31.0	2.0	6	22.0	14.0	16.0	8.0	1.6	9.2
40	55.5	51	58	4	64	45.0	31.0	2.0	6	22.0	14.0	16.0	8.0	1.6	9.2
43	57.5	54	61	4	67	45.0	31.0	2.0	6	22.0	14.0	16.0	8.0	1.6	9.2
45	58.7	56	63	4	69	45.0	31.0	2.0	6	22.0	14.0	16.0	8.0	1.6	9.5
48	61.9	59	66	4	72	45.0	31.0	2.0	6	22.0	14.0	16.0	8.0	1.6	9.2
50	65.0	62	70	4	74	47.5	32.5	2.5	6	23.0	15.0	17.0	9.5	1.6	10.5
53	68.2	65	73	4	77	47.5	32.5	2.5	6	23.0	15.0	17.0	9.5	1.6	10.5
55	70.0	67	75	4	80	47.5	32.5	2.5	6	23.0	15.0	17.0	9.5	1.6	10.0
58	71.7	70	78	4	83	52.5	37.5	2.5	6	23.0	15.0	18.0	10.5	3.0	14.0
60	74.6	72	80	4	85	52.5	37.5	2.5	6	23.0	15.0	18.0	10.5	3.0	14.0
63	79.0	75	83	4	88	52.5	37.5	2.5	6	23.0	15.0	18.0	10.5	3.0	14.0
65	84.1	77	85	4	95	52.5	37.5	2.5	6	23.0	15.0	18.0	10.5	3.0	14.0
68	87.3	81	90	4	96	52.5	34.5	2.5	7	26.0	18.0	18.5	11.0	1.6	10.0
70	87.3	83	92	4	96	60.0	42.0	2.5	7	26.0	18.0	19.0	11.5	3.0	17.0
75	95.0	88	97	4	104	60.0	42.0	2.5	7	26.0	18.0	19.0	11.5	3.0	16.0
80	98.4	95	105	4	109	60.0	41.8	3.0	7	26.2	18.2	19.0	11.5	3.0	16.0
85	104.7	100	110	4	114	60.0	41.8	3.0	7	26.2	18.2	19.0	11.5	3.0	16.0
90	111.0	105	115	4	119	65.0	46.8	3.0	7	26.2	18.2	20.5	13.0	3.0	21.0
95	114.0	110	120	4	124	65.0	47.8	3.0	7	25.2	17.2	20.5	13.0	3.0	21.0
100	117.4	115	125	4	129	65.0	47.8	3.0	7	25.2	17.2	20.5	13.0	3.0	20.0

Dimensions in millimeter

* Installation length is longer than l_{1K} specified by EN 12756