

## basic mixer cartridge seal range



- **BALANCED SEAL FACE DESIGN**
- **MODULAR DESIGN**
- **NO SHAFT FRETTING**
- **BALANCED SEAL FACES**
- **NON-CLOGGING ROTARIES**

## Basic Mixer Cartridge Seal Ranges

**This brochure covers the range of AESSEAL® basic Mixer cartridge seals designed for Mixers, Agitators and Reactors. This range has been designed to accept and accommodate the prevalent conditions in mixing and associated applications.**

Mixer, Agitator and Reactor applications vary from simple blending or solid dissolution to the more exacting standards of solids suspension, gas dispersion or containing/promoting chemical reactions.

The basic mixer range covers unit seals, cartridge seals, non-metallic seals and seals with and without bearings.

Mixers are used in the Food, Beverage and Pharmaceutical industries, yet generally the Chemical and Process industries have the most varied and difficult mixer problems and, therefore, require precise sealing technology. The AESSEAL® mixer seal range ensures that the most demanding applications can be accommodated.

### Advanced Mixer Cartridge Seal Range

AESSEAL® also produce a Mixmaster brochure for the top end of the range which have high load carrying capabilities. We also produce a Mixer, Agitator & Reactor seal range booklet which incorporates more specialized seals for this industry as well as in depth case histories of seals.

For more information these brochures can be downloaded from the AESSEAL® website at [www.aesseal.com](http://www.aesseal.com).

### Development Background

The AESSEAL® Mixmaster range has been developed only after extensive performance and field evaluation tests, conducted over many years.

The range has been created using the latest Computer Aided Design and Manufacture programmes including Finite Element Analysis.

These programmes help to predict how the seals can be produced and also how they will perform under various application conditions. This technology has vastly reduced the lead time for product development and thus reduced the overall cost of the seal range.

Computer Generated  
Mixmaster I™  
(CSWIB™ Type C)  
3D Model

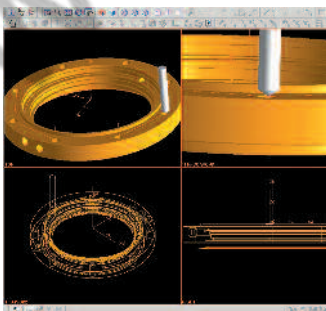

Massive investment in Computer Aided Design, Manufacture and PDM (Product Data Management) helps to ensure that the seal is fit for the purpose.

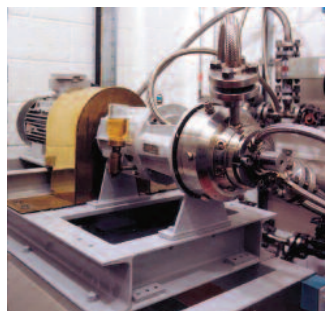

Computer simulation is very effective for evaluating seal performance, however, all AESSEAL® mechanical seals still have to undergo physical testing in various hazardous conditions.

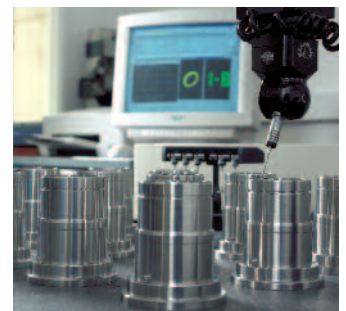

Investment in inspection facilities which include the latest Co-ordinate Measuring Machines (CMM) allow computer controlled inspection for all AESSEAL® designs. The result is an industry leading range of mechanical seals.

# ESM™ - External Seal for Mixers



The AESSEAL® ESM™ is a unit external seal designed for ease of installation as the faces are clipped together and despatched assembled in a leak free state.

The standard ESM™ seal is driven through socket set screw clamping, with a Carbon/Ceramic seal face combination and a gland which is designed to suit the customer's equipment.

All wetted parts are non-metallic, therefore, the seal is ideally suited for corrosive vapour applications commonly found in Top Entry Mixers.

- **Balanced seal face design**
- **Modular design**
- **Unit designed for ease of installation**
- **ESM™, ESCM™, ESTM™, ESCTM™ non-metallic wetted design**
- **NCM™ non-chemical design**
- **Springs out of product**
- **Seal flange manufactured to suit equipment**



**ESM™**  
External Seal for Mixers

<b>Sizes Available</b>	1.000" to 2.500"	25mm to 63mm
------------------------	------------------	--------------

**NCM™**  
Non-Chemical for Mixers

<b>Sizes Available</b>	1.000" to 5.000"	24mm to 125mm
------------------------	------------------	---------------

**ESTM™**  
External Seal Teflon for Mixers

<b>Sizes Available</b>	1.000" to 2.500"	25mm to 63mm
------------------------	------------------	--------------

Designed for ease of installation the ESM™ has non-metallic wetted parts and is therefore ideally suited for corrosive vapour applications commonly found in Top Entry Mixers.

The NCM™ is an external seal unit designed for ease of installation, as the faces are clipped together and despatched assembled in a leak free state. Some wetted parts are metallic, therefore the seal is unsuited for some severe corrosive applications.

A sister variant on the ESM™, the ESTM™ replaces the Carbon/Ceramic face combination with Teflon (P.T.F.E.)/Ceramic, for applications where Carbon is not compatible with the process fluid.

**ESCM™**  
External Seal Colleted for Mixers

<b>Sizes Available</b>	1.000" to 2.500"	25mm to 63mm
------------------------	------------------	--------------

**Buffer Canister™ Option**

Buffer Canister™ option available on ESM™ - NCM™ - ESTM™ - ESCM™ - ESCTM™

**ESCTM™ - External Seal Colleted Teflon for Mixers**

<b>Sizes Available</b>	1.000" to 2.500"	25mm to 63mm
------------------------	------------------	--------------

The ESCM™ employs the same seal principles as the ESM™ except for the clamping device. The ESCM™ utilises a collet clamp ring making the unit particularly applicable to hard and soft shafts.

The buffer canister option is available on both the ESM™ and NCM™ range of unit seals. The simple design can be of an open or closed top construction and slides over the external seal. An O-ring is then placed in the clip groove to prevent leakage. The fluid in the canister "bathes" the seal faces and therefore is applicable for the dry running applications which are commonly found in top entry mixers.

A hybrid unit seal of the previous options. The ESCTM™ offers a Teflon/Ceramic face combination, collet clamping and gland designed to suit the customer's equipment. All wetted parts are non-metallic.

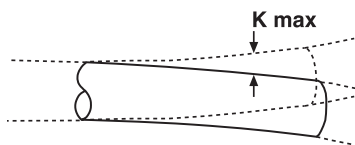

ESM™ - ESCM™ - ESTM™ - ESCTM™	
Seal Size	T.I.R. (K max)
1.000" to 1.500"	0.030"
25mm to 38mm	0.8mm
1.625" to 2.500"	0.040"
40mm to 63mm	1.0mm

Seal Type	Face Availability	Drive
ESM™	CAR - CER	Standard
ESCM™	CAR - CER	Collet
ESTM™	PTFE - CER	Standard
ESCTM™	PTFE - CER	Collet
<b>Rotary Face</b>		
NCM™	Car - SIC - TC	Standard
<b>Stationary Face</b>		
CROX-CER-SIC-TC		

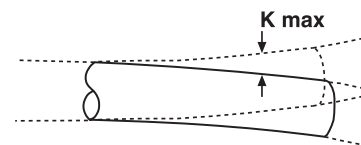

NCM™	
Seal Size	T.I.R. (K max)
1.000" to 2.375"	0.040"
24mm to 60mm	1.0mm
2.500" to 5.000"	0.060"
40mm to 63mm	1.5mm

# Mixmaster I™ - CSWIB™

The AESSEAL® Mixmaster I™ is a single cartridge mechanical seal, with balanced seal faces and an integral (steady) bearing.

The Mixmaster I™ can be ordered in types B, C & D in a variety of gland combinations concerning flush, quench, drain and grease connections and also different face combinations. The gland plate is machined to meet the customer's requirements with respect to outside diameter, bolt circle diameter and stuffing box location.

## Type B

Quench, Drain & Grease Connections

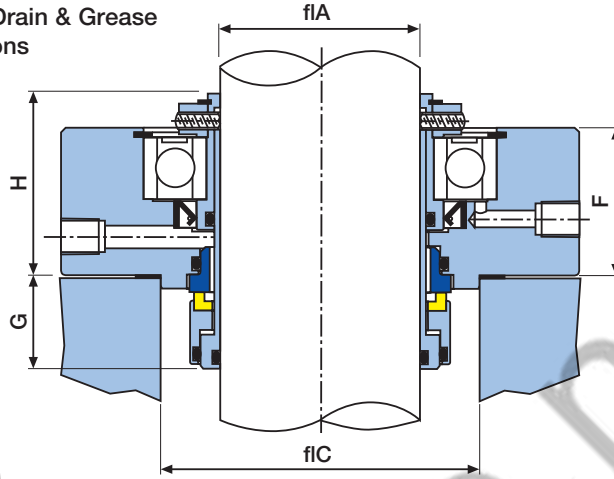

## Type C

Type B Design with Flush

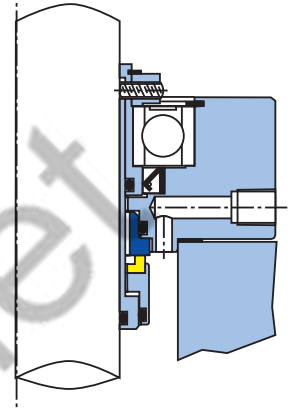

## Type D

Exotic Alloy Option with Quench, Drain & Grease Connections

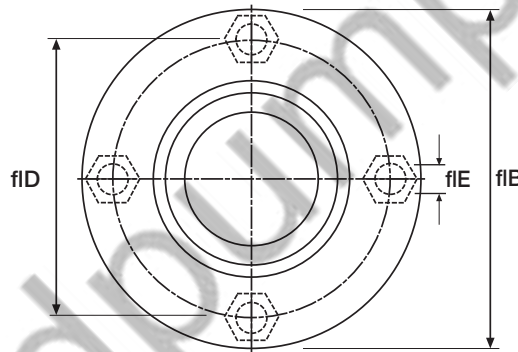
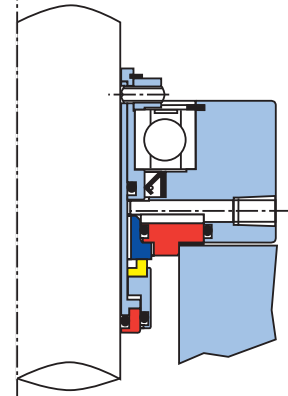

Minimum bolt circle based on bolt size shown.

CSWIB™ - Dimensional Information (inches)

ØA	ØB	ØC		ØD		ØE	F	G	H
		Min	Max	Min	Max				
1.000	1.663	3.000		3/8	1.750	1.150	2.312		
1.125	1.780	3.250		3/8	1.750	1.150	2.312		
1.250	1.931	3.500		3/8	1.750	1.150	2.312		
1.375	2.056	3.500		3/8	1.750	1.150	2.312		
1.500	2.303	3.875		1/2	1.812	1.187	2.375		
1.625	2.428	4.500		1/2	1.812	1.187	2.375		
1.750	2.553	4.500		1/2	1.812	1.187	2.375		
1.875	2.678	4.625		1/2	1.812	1.312	2.375		
2.000	2.803	4.625		1/2	1.812	1.312	2.375		
2.125	2.928	4.937		1/2	1.812	1.312	2.375		
2.250	3.053	5.000		5/8	1.812	1.312	2.375		
2.375	3.178	5.375		5/8	1.812	1.312	2.375		
2.500	3.428	5.500		5/8	2.000	1.312	2.625		
2.625	3.553	5.500		5/8	2.000	1.312	2.625		
2.750	3.678	5.875		5/8	2.062	1.312	2.625		
2.875	3.803	6.125		5/8	2.062	1.312	2.625		
3.000	3.928	6.125		5/8	2.062	1.312	2.625		
3.125	4.053	6.500		5/8	2.062	1.312	2.625		
3.250	4.178	6.625		3/4	2.062	1.312	2.625		
3.375	4.303	6.875		3/4	2.062	1.312	2.625		
3.500	4.428	6.875		3/4	2.062	1.312	2.625		
3.625	4.553	7.375		3/4	2.062	1.312	2.625		
3.750	4.678	7.375		3/4	2.062	1.312	2.625		
3.875	4.803	7.875		3/4	2.125	1.312	2.625		
4.000	4.928	7.875		3/4	2.125	1.312	2.625		

Note: ØE, F, G, H are typical sizes only. This seal design is made to suit customer requirements and these sizes can be changed.

CSWIB™ - Dimensional Information (mm)

ØA	ØB	ØC		ØD		ØE	F	G	H
		Min	Max	Min	Max				
24		41.2		76.2		10	44.5	29.2	58.7
25		42.2		76.2		10	44.5	29.2	58.7
28		45.2		82.6		10	44.5	29.2	58.7
30		47.2		82.6		10	44.5	29.2	58.7
32		49.0		88.9		10	44.5	29.2	58.7
33		49.0		88.9		10	44.5	29.2	58.7
35		52.2		88.9		10	44.5	29.2	58.7
38		58.5		98.4		12	46.0	30.1	60.3
40		58.5		98.4		12	46.0	30.1	60.3
43		61.7		114.3		12	46.0	30.1	60.3
45		64.8		114.3		12	46.0	30.1	60.3
48		68.0		117.5		12	46.0	33.3	60.3
50		68.0		117.5		12	46.0	33.3	60.3
53		71.2		117.5		12	46.0	33.3	60.3
55		74.4		125.4		12	46.0	33.3	60.3
58		77.5		136.5		16	46.0	33.3	60.3
60		80.7		136.5		16	46.0	33.3	60.3
63		87.1		139.7		16	50.8	33.3	66.7
65		90.2		139.7		16	50.8	33.3	66.7
68		93.4		149.2		16	52.4	33.3	66.7
70		93.4		149.2		16	52.4	33.3	66.7
75		99.8		155.6		16	52.4	33.3	66.7
80		102.9		165.1		16	52.4	33.3	66.7
85		109.3		174.6		20	52.4	33.3	66.7
90		115.6		187.3		20	52.4	33.3	66.7
95		118.8		187.3		20	52.4	33.3	66.7
100		125.2		200.0		20	54.0	33.3	66.7



# Mixmaster II™ - DSWIB™

The AESSEAL® Mixmaster II™ is a double cartridge seal with integral bearing design with concentric faces so that the seals overall length is reduced.

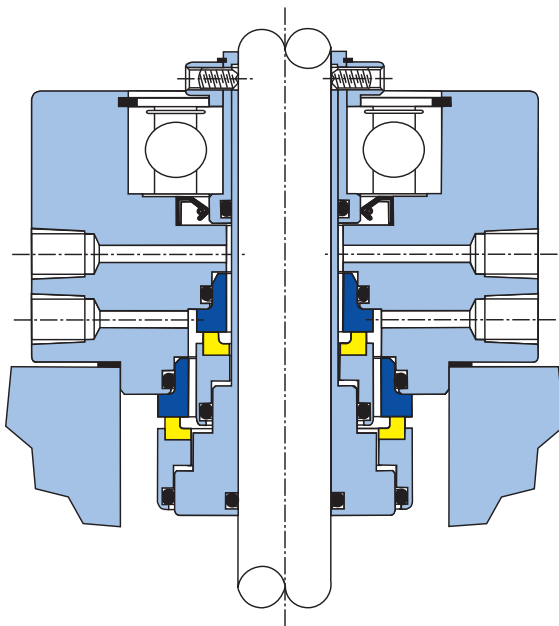

The CSWIB™ & DSWIB™ are offered with the following features:

- The integral bearing (pre-installed) is designed as a steady bearing and may not take the full radial load applied to a mixer
- Quench drain & grease connections as standard
- Available with flush connection (type 'C' only)
- No shaft fretting
- Balanced seal faces
- Non-clogging rotaries
- Most suitable for low shaft speeds
- Supplied with high tensile, corrosion resistant socket set screws

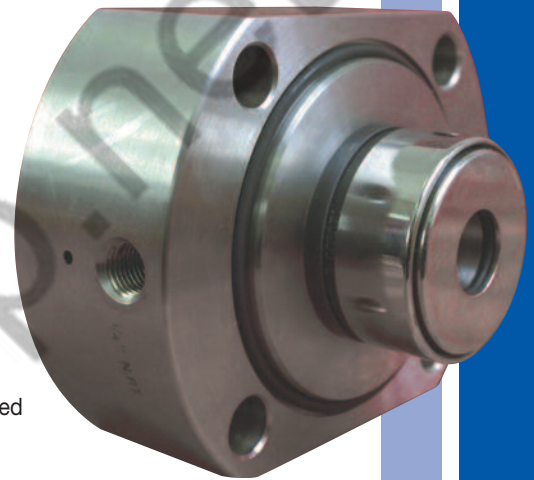

**DSWIB™ - (inches)**

ØA	ØB	ØC	
		Min	Max
1.000		2.303	
1.125		2.428	
1.250		2.553	
1.375		2.678	
1.500		2.928	
1.625	Dependent upon application	3.053	Dependent upon application
1.750		3.178	
1.875		3.428	
2.000		3.553	
2.125		3.678	
2.250		3.803	
2.375		3.928	
2.500		4.178	
2.625		4.303	
2.750		4.428	
2.875	4.553		
3.000	4.678		
3.125	4.803		
3.250	4.928		
3.375	5.178		
3.500	5.178		
3.625	5.428		
3.750	5.428		
3.875	5.678		
4.000	5.678		

**DSWIB™ - (mm)**

ØA	ØB	ØC	
		Min	Max
24		58.5	
25		58.5	
28		61.7	
30		61.7	
32		64.8	
33	Dependent upon application	64.8	Dependent upon application
35		68.0	
38		74.4	
40		74.4	
43		77.5	
45		80.7	
48		87.1	
50		87.1	
53		90.2	
55		93.4	
58	96.6		
60	99.8		
63	106.1		
65	109.3		
68	112.5		
70	112.5		
75	118.8		
80	122.0		
85	131.5		
90	137.9		
95	137.9		
100	144.2		

The Mixmaster II™ can be ordered in types B, C & D.

Like the Mixmaster I™, the Mixmaster II™ seal is manufactured from a fully machined gland, to the customer's specification.

**Note:** All face combinations up to 3.250" are standard AESSEAL® face materials. Contact the AESSEAL® technical department for hard face options above this size.

When ordering a CSWIB™ or DSWIB™ seal, please state accurately the following details: STUFFING BOX BORE - QUANTITY, SIZE AND SPACING OF BOLTS and BOLT CIRCLE DIAMETER. Please read and quote document Ref. AW 0810 and complete a seal application form with all enquiries. This can be obtained from [marketing@aes seal.com](mailto:marketing@aes seal.com).

## Environmental Control Systems for double seals

In addition to a vast range of mechanical seals, AESSEAL® has a specialized systems division, dedicated to the design and manufacture of a comprehensive range of seal support packages for double mechanical seals. These support systems range from Thermosyphon systems, SWFF-TF™, Flow True™ and AES-15™ to the fully featured forced circulation system FDU™ for use on oil and water applications.

**SWFF-TF™**



**Flow True™**



**AES-15™**



**FDU™**



The systems above are compatible with a wide selection of barrier and buffer fluid media. They are supplied pre-assembled with all necessary components and fittings. On site inventory costs are reduced by modular system construction.

# CSM™ - Cartridge Single for Mixers

The AESSEAL® CSM™ is available in a wide range of seal face, elastomer and alloy combinations, to suit individual applications.

Single cartridge seal for mixers/agitators.

Designed to run in vapour on vertical applications, with low emissions

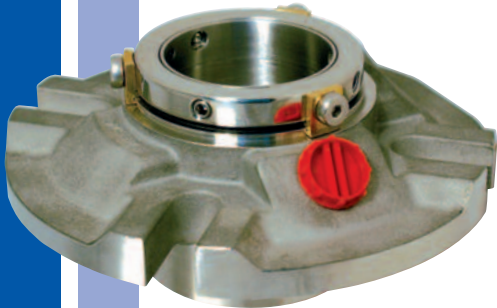

## CSM™ - Dimensional Information (inches)

A	B	C	D	E	Min	F	Max	Min	G	Max	H	I	J	K	Max
1.000	4.125	2.125	1.937	0.519	1.625	1.665	1.937	2.687	3.562	1/2	1.125	1.590	0.040		
1.125	4.250	2.250	2.063	0.519	1.750	1.790	2.062	2.812	3.687	1/2	1.125	1.590	0.040		
1.250	4.375	2.375	2.187	0.519	1.875	1.915	2.187	2.937	3.812	1/2	1.125	1.590	0.040		
1.375	4.375	2.500	2.312	0.519	2.000	2.040	2.250	3.062	3.812	1/2	1.125	1.590	0.040		
1.500	5.000	2.812	2.562	0.644	2.250	2.290	2.375	3.375	4.437	1/2	1.125	1.752	0.040		
1.625	5.000	2.812	2.562	0.644	2.375	2.415	2.500	3.375	4.437	1/2	1.125	1.752	0.040		
1.750	5.500	3.187	2.812	0.644	2.500	2.540	2.750	3.750	4.937	1/2	1.125	1.752	0.040		
1.875	5.500	3.187	2.812	0.644	2.625	2.665	2.875	3.750	4.937	1/2	1.125	1.752	0.040		
2.000	6.000	3.562	3.063	0.644	2.750	2.790	3.000	4.125	5.437	1/2	1.125	1.752	0.040		
2.000-AC	5.250	3.450	3.035	0.644	2.750	2.790	3.000	4.000	4.750	1/2	1.125	1.752	0.040		
2.125	6.000	3.562	3.063	0.644	2.875	2.915	3.125	4.125	5.437	1/2	1.125	1.752	0.040		
2.250	6.500	3.812	3.312	0.644	3.000	3.040	3.250	4.500	5.812	5/8	1.125	1.752	0.040		
2.375	6.500	3.812	3.312	0.644	3.125	3.165	3.375	4.500	5.812	5/8	1.125	1.752	0.040		
2.500	7.000	4.312	3.812	0.769	3.375	3.435	3.625	5.000	6.312	5/8	1.250	1.877	0.060		
2.625	7.000	4.312	3.812	0.769	3.500	3.560	3.750	5.000	6.312	5/8	1.250	1.877	0.060		
2.750	7.000	4.312	3.812	0.769	3.625	3.685	3.875	5.000	6.312	5/8	1.250	1.877	0.060		
2.875	7.500	4.937	4.250	0.769	3.750	3.810	4.125	5.625	6.812	5/8	1.250	1.877	0.060		
3.000	7.500	4.937	4.250	0.769	3.875	3.935	4.250	5.625	6.812	5/8	1.250	1.877	0.060		
3.125	7.500	4.937	4.250	0.769	4.000	4.060	4.375	5.625	6.812	5/8	1.250	1.877	0.060		
3.250	8.000	5.312	4.625	0.769	4.125	4.185	4.500	6.125	7.187	3/4	1.250	1.877	0.060		
3.375	8.000	5.312	4.625	0.769	4.250	4.310	4.625	6.125	7.187	3/4	1.250	1.877	0.060		
3.500	8.000	5.312	4.625	0.769	4.375	4.435	4.750	6.125	7.187	3/4	1.250	1.877	0.060		
3.625	8.500	5.937	5.000	0.769	4.500	4.560	5.000	6.750	7.687	3/4	1.250	1.877	0.060		
3.750	8.500	5.937	5.000	0.769	4.625	4.685	5.125	6.750	7.687	3/4	1.250	1.877	0.060		
3.875	8.500	5.937	5.000	0.769	4.750	4.810	5.250	6.750	7.687	3/4	1.250	1.877	0.060		
4.000	9.000	6.625	5.375	0.769	4.875	4.935	5.500	7.437	8.187	3/4	1.250	1.877	0.060		
4.125	9.000	6.625	5.375	0.769	5.125	5.185	5.875	7.437	8.187	3/4	1.250	1.877	0.060		
4.250	9.000	6.625	5.375	0.769	5.125	5.185	5.875	7.437	8.187	3/4	1.250	1.877	0.060		
4.375	9.500	7.000	5.750	0.769	5.375	5.435	6.250	7.812	8.687	3/4	1.250	1.877	0.060		
4.500	9.500	7.000	5.750	0.769	5.375	5.435	6.250	7.812	8.687	3/4	1.250	1.877	0.060		
4.625	10.000	7.345	6.125	0.769	5.625	5.685	6.625	8.312	9.062	7/8	1.250	1.877	0.060		
4.750	10.000	7.345	6.125	0.769	5.625	5.685	6.625	8.312	9.062	7/8	1.250	1.877	0.060		
4.875	10.000	7.345	6.125	0.769	5.875	5.935	6.625	8.312	9.062	7/8	1.250	1.877	0.060		
5.000	10.000	7.345	6.125	0.769	5.875	5.935	6.625	8.312	9.062	7/8	1.250	1.877	0.060		

Seal sizes from 5.125" to 12.000" are designed to suit specific equipment using modular components. Contact AESSEAL® technical department for dimensional information and availability.

† = F Min + K Max

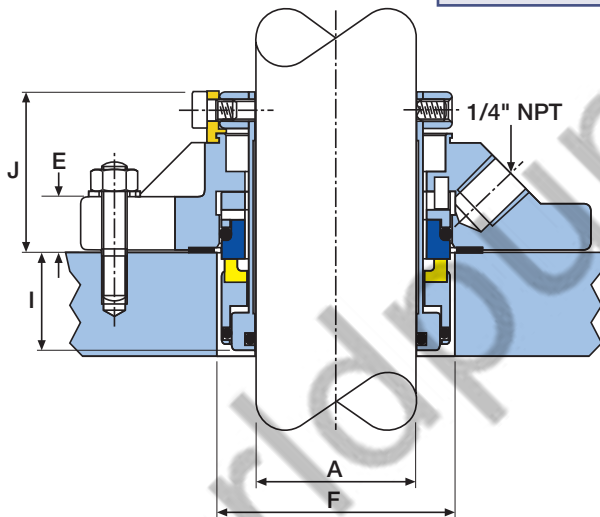

## CSM™ - Dimensional Information (mm)

A	B	C	D	E	Min	F	Max	Min	G	Max	H	I	J	K	Max
24	104.8	54.0	49.2	13.2	41.0	41.0	46.0	67.0	90.5	12	28.6	40.5	1.0		
25	104.8	54.0	49.2	13.2	41.0	42.0	49.0	67.0	90.5	12	28.6	40.5	1.0		
28	108.0	57.2	52.4	13.2	44.0	45.0	52.3	70.3	93.6	12	28.6	40.5	1.0		
30	111.0	60.4	55.6	13.2	46.0	47.0	55.5	73.5	96.8	12	28.6	40.5	1.0		
32	111.0	60.4	55.6	13.2	48.0	49.0	55.5	73.5	96.8	12	28.6	40.5	1.0		
33	111.0	60.4	55.6	13.2	49.0	50.0	55.5	73.5	96.8	12	28.6	40.5	1.0		
35	111.0	63.5	58.8	13.2	51.0	52.0	57.5	76.6	96.8	12	28.6	40.5	1.0		
38	127.0	71.5	65.0	16.4	57.2	58.2	60.4	85.7	114.3	12	28.6	44.5	1.0		
40	127.0	71.5	65.0	16.4	58.0	59.0	60.4	85.7	114.3	12	28.6	44.5	1.0		
43	139.7	81.0	71.4	16.4	61.0	62.0	69.9	95.3	127.0	12	28.6	44.5	1.0		
45	139.7	81.0	71.4	16.4	63.5	64.5	69.9	95.3	127.0	12	28.6	44.5	1.0		
48	139.7	81.0	71.4	16.4	66.7	67.7	73.0	95.3	127.0	12	28.6	44.5	1.0		
50	152.4	90.5	77.8	16.4	68.0	69.0	76.2	104.8	139.7	12	28.6	44.5	1.0		
53	152.4	90.5	77.8	16.4	71.0	72.0	76.2	104.8	139.7	12	28.6	44.5	1.0		
55	165.1	96.8	84.1	16.4	74.0	75.0	82.5	114.3	149.2	16	28.6	44.5	1.0		
58	165.1	96.8	84.1	16.4	76.2	77.2	82.5	114.3	149.2	16	28.6	44.5	1.0		
60	165.1	96.8	84.1	16.4	78.4	80.4	85.7	114.3	149.2	16	28.6	44.5	1.0		
63	177.8	109.5	96.8	19.6	85.8	87.3	92.1	127.0	160.3	16	31.8	47.7	1.5		
65	177.8	109.5	96.8	19.6	88.9	90.4	95.3	127.0	160.3	16	31.8	47.7	1.5		
68	177.8	109.5	96.8	19.6	92.1	93.6	98.4	127.0	160.3	16	31.8	47.7	1.5		
70	177.8	109.5	96.8	19.6	92.1	93.6	98.4	127.0	160.3	16	31.8	47.7	1.5		
75	190.5	125.4	108.0	19.6	96.5	100.0	108.0	142.9	173.0	16	31.8	47.7	1.5		
80	190.5	125.4	108.0	19.6	101.6	103.1	111.1	142.9	173.0	16	31.8	47.7	1.5		
85	203.2	135.0	117.5	19.6	108.0	109.5	117.5	155.6	182.5	20	31.8	47.7	1.5		
90	215.9	150.8	127.0	19.6	114.3	115.8	127.0	171.5	195.2	20	31.8	47.7	1.5		
93	215.9	150.8	127.0	19.6	117.5	119.0	130.2	171.5	195.2	20	31.8	47.7	1.5		
100	228.6	168.3	136.5	19.6	123.9	125.4	139.7	188.9	208.0	20	31.8	47.7	1.5		
105	228.6	168.3	136.5	19.6	130.1	131.6	149.2	188.9	208.0	20	31.8	47.7	1.5		
110	241.3	177.8	146.1	19.6	136.5	138.0	158.8	198.4	220.6	20	31.8	47.7	1.5		
115	254.0	186.6	155.8	19.6	142.9	144.4	168.3	211.1	230.2	22	31.8	47.7	1.5		
120	254.0	186.6	155.8	19.6	142.9	144.4	168.3	211.1	230.2	22	31.8	47.7	1.5		
125	254.0	186.6	155.8	19.6	149.2	150.7	168.3	211.1	230.2	22	31.8	47.7	1.5		

Seal sizes from 130mm to 300mm are designed to suit specific equipment using modular components. Contact AESSEAL® technical department for dimensional information and availability.

† = F Min + K Max

## CSM™ - Dry Running

D1	D2	D3	D4	D5			
mm	inch	barg	psig	bar m/s			
25	1.0	300	2	29.4	1.2	3370	70000
25	1.0	600	2	29.4	2.4	6740	40000
25	1.0	900	2	29.4	3.5	10100	14000
25	1.0	300	4	58.7	2.0	5600	50000
25	1.0	600	4	58.7	3.9	11130	9000
25	1.0	300	6	88.1	2.8	7850	21000
50	2.0	300	2	29.4	2.4	6740	40000
50	2.0	600	2	29.4	4.7	13480	6800
50	2.0	300	4	58.7	3.9	11130	9000
50	2.0	100	6	88.1	1.8	5220	50000
50	2.0	200	6	88.1	2.7	7590	21000
75	3.0	100	2	29.4	1.2	3430	70000
75	3.0	300	2	29.4	3.0	8570	16000
75	3.0	100	4	58.7	2.0	5600	40000
75	3.0	100	6	88.1	2.8	7850	21000
100	4.0	100	2	29.4	1.6	4570	60000
100	4.0	200	2	29.4	3.2	9140	21000
100	4.0	100	4	58.7	2.6	7420	30000
100	4.0	50	6	88.1	1.8	5140	70000
100	4.0	100	6	88.1	3.6	10280	13000

The above chart shows a summary of the expected life time for dry running performance of Carbon/Silicon Carbide faces.

D1:	D2:	D3:	D4:	D5:
Shaft Diameter	Shaft Speed (rpm)	Product Pressure	'P.V.' Value</	

# CDM™ - Cartridge Double for Mixers

The AESSEAL® CDM™ is available in a wide range of seal face, elastomer and alloy combinations, to suit individual applications.



## CDM™ - Dimensional Information (inches)

A	B	C	D	E	F			G		H	I	J	K
					Min	Min†	Max	Min	Max	Max			Max
1.000	4.125	2.125	1.937	0.519	1.625	1.665	1.937	2.687	3.562	1/2	1.281	2.062	0.040
1.125	4.250	2.250	2.063	0.519	1.750	1.790	2.062	2.812	3.687	1/2	1.281	2.062	0.040
1.250	4.375	2.375	2.187	0.519	1.875	1.915	2.187	2.937	3.812	1/2	1.281	2.062	0.040
1.375	4.375	2.500	2.312	0.519	2.000	2.040	2.250	3.062	3.812	1/2	1.281	2.062	0.040
1.500	5.000	2.812	2.562	0.644	2.250	2.290	2.375	3.375	4.437	1/2	1.312	2.125	0.040
1.625	5.000	2.812	2.562	0.644	2.375	2.415	2.500	3.375	4.437	1/2	1.312	2.125	0.040
1.750	5.500	3.187	2.812	0.644	2.500	2.540	2.750	3.750	4.937	1/2	1.312	2.125	0.040
1.875	5.500	3.187	2.812	0.644	2.625	2.665	2.875	3.750	4.937	1/2	1.312	2.125	0.040
2.000	6.000	3.562	3.063	0.644	2.750	2.790	3.000	4.125	5.437	1/2	1.380	2.125	0.040
2.000-AC	5.250	3.450	3.035	0.644	2.750	2.790	3.000	4.000	4.750	1/2	1.380	2.125	0.040
2.125	6.000	3.562	3.063	0.644	2.875	2.915	3.125	4.125	5.437	1/2	1.380	2.125	0.040
2.250	6.500	3.812	3.312	0.644	3.000	3.040	3.250	4.500	5.812	5/8	1.380	2.125	0.040
2.375	6.500	3.812	3.312	0.644	3.125	3.165	3.375	4.500	5.812	5/8	1.380	2.125	0.040
2.500	7.000	4.312	3.812	0.769	3.375	3.435	3.625	5.000	6.312	5/8	1.500	2.375	0.060
2.625	7.000	4.312	3.812	0.769	3.500	3.560	3.750	5.000	6.312	5/8	1.500	2.375	0.060
2.750	7.000	4.312	3.812	0.769	3.625	3.685	3.875	5.000	6.312	5/8	1.500	2.375	0.060
2.875	7.500	4.937	4.250	0.769	3.750	3.810	4.125	5.625	6.812	5/8	1.500	2.375	0.060
3.000	7.500	4.937	4.250	0.769	3.875	3.935	4.250	5.625	6.812	5/8	1.500	2.375	0.060
3.125	7.500	4.937	4.250	0.769	4.000	4.060	4.375	5.625	6.812	5/8	1.500	2.375	0.060
3.250	8.000	5.312	4.625	0.769	4.125	4.185	4.500	6.125	7.187	3/4	1.500	2.375	0.060
3.375	8.000	5.312	4.625	0.769	4.250	4.310	4.625	6.125	7.187	3/4	1.500	2.375	0.060
3.500	8.000	5.312	4.625	0.769	4.375	4.435	4.750	6.125	7.187	3/4	1.500	2.375	0.060
3.625	8.500	5.937	5.000	0.769	4.500	4.560	5.000	6.750	7.687	3/4	1.500	2.375	0.060
3.750	8.500	5.937	5.000	0.769	4.625	4.685	5.125	6.750	7.687	3/4	1.500	2.375	0.060
3.875	8.500	5.937	5.000	0.769	4.750	4.810	5.250	6.750	7.687	3/4	1.500	2.375	0.060
4.000	9.000	6.625	5.375	0.769	4.875	4.935	5.500	7.437	8.187	3/4	1.500	2.375	0.060
4.125	9.000	6.625	5.375	0.769	5.125	5.185	5.875	7.437	8.187	3/4	1.500	2.375	0.060
4.250	9.000	6.625	5.375	0.769	5.125	5.185	5.875	7.437	8.187	3/4	1.500	2.375	0.060
4.375	9.500	7.000	5.750	0.769	5.375	5.435	6.250	7.812	8.687	3/4	1.500	2.375	0.060
4.500	9.500	7.000	5.750	0.769	5.375	5.435	6.250	7.812	8.687	3/4	1.500	2.375	0.060
4.625	10.000	7.345	6.125	0.769	5.625	5.685	6.625	8.312	9.062	7/8	1.500	2.375	0.060
4.750	10.000	7.345	6.125	0.769	5.625	5.685	6.625	8.312	9.062	7/8	1.500	2.375	0.060
4.875	10.000	7.345	6.125	0.769	5.875	5.935	6.625	8.312	9.062	7/8	1.500	2.375	0.060
5.000	10.000	7.345	6.125	0.769	5.875	5.935	6.625	8.312	9.062	7/8	1.500	2.375	0.060

Double cartridge seal for mixers/agitators.



† = F Min + K Max

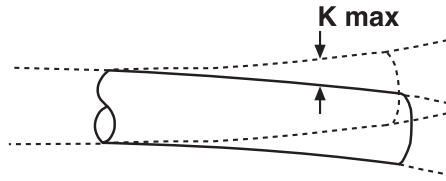

K Max = Maximum TOTAL Radial Movement

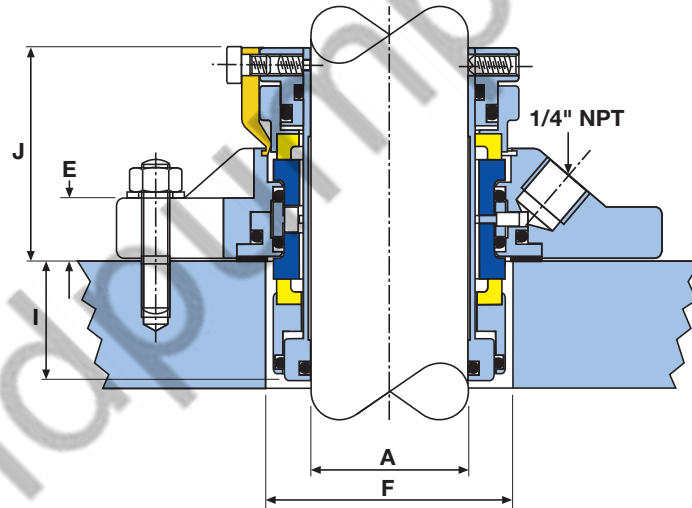

## CDM™ - Dimensional Information (mm)

A	B	C	D	E	F			G		H	I	J	K
					Min	Min†	Max	Min	Max	Max			Max
24	104.8	54.0	49.2	13.2	40.0	41.0	46.0	67.0	90.5	12	32.5	52.4	1.0
25	104.8	54.0	49.2	13.2	41.0	42.0	49.0	67.0	90.5	12	32.5	52.4	1.0
28	108.0	57.2	52.4	13.2	44.0	45.0	52.3	70.3	93.6	12	32.5	52.4	1.0
30	111.0	60.4	55.6	13.2	46.0	47.0	55.5	73.5	96.8	12	32.5	52.4	1.0
32	111.0	60.4	55.6	13.2	48.0	49.0	55.5	73.5	96.8	12	32.5	52.4	1.0
33	111.0	60.4	55.6	13.2	49.0	50.0	55.5	73.5	96.8	12	32.5	52.4	1.0
35	111.0	63.5	58.8	13.2	51.0	52.0	57.5	76.6	96.8	12	32.5	52.4	1.0
38	127.0	71.5	65.0	16.4	57.2	58.2	60.3	85.7	114.3	12	33.3	54.0	1.0
40	127.0	71.5	65.0	16.4	58.0	59.0	60.4	85.7	114.3	12	33.3	54.0	1.0
43	127.0	71.5	65.0	16.4	61.0	62.0	63.5	85.7	114.3	12	33.3	54.0	1.0
45	139.7	81.0	71.4	16.4	63.5	64.5	69.9	95.3	127.0	12	33.3	54.0	1.0
48	139.7	81.0	71.4	16.4	66.7	67.7	73.0	95.3	127.0	12	33.3	54.0	1.0
50	139.7	81.0	71.4	16.4	68.0	69.0	73.0	95.3	127.0	12	33.3	54.0	1.0
53	152.4	90.5	77.8	16.4	71.0	72.0	76.2	104.8	139.7	12	35.0	54.0	1.0
55	152.4	90.5	77.8	16.4	74.0	75.0	79.4	104.8	139.7	12	35.0	54.0	1.0
58	165.1	96.8	84.1	16.4	76.2	77.2	82.5	114.3	149.2	16	35.0	54.0	1.0
60	165.1	96.8	84.1	16.4	79.4	80.4	85.7	114.3	149.2	16	35.0	54.0	1.0
63	177.8	109.5	96.8	19.6	85.8	87.3	92.1	127.0	160.3	16	38.1	60.3	1.5
65	177.8	109.5	96.8	19.6	88.9	90.4	95.3	127.0	160.3	16	38.1	60.3	1.5
68	177.8	109.5	96.8	19.6	92.1	93.6	98.4	127.0	160.3	16	38.1	60.3	1.5
70	177.8	109.5	96.8	19.6	92.1	93.6	98.4	127.0	160.3	16	38.1	60.3	1.5
75	190.5	125.4	108.0	19.6	98.5	100.0	108.0	142.9	173.0	16	38.1	60.3	1.5
80	190.5	125.4	108.0	19.6	101.6	103.1	111.1	142.9	173.0	16	38.1	60.3	1.5
85	203.2	135.0	117.5	19.6	108.0	109.5	117.5	155.6	182.5	20	38.1	60.3	1.5
90	215.9	150.8	127.0	19.6	114.3	115.8	127.0	171.5	195.2	20	38.1	60.3	1.5
95	215.9	150.8	127.0	19.6	117.5	119.0	130.2	171.5	195.2	20	38.1	60.3	1.5
100	228.6	169.3	136.5	19.6	123.9	125.4	139.7	189.9	208.0	20	38.1	60.3	1.5
105	228.6	169.3	136.5	19.6	130.1	131.6	149.2	189.9	208.0	20	38.1	60.3	1.5
110	241.3	177.8	146.1	19.6	136.5	138.0	158.8	198.4	220.2	20	38.1	60.3	1.5
115	254.0	186.6	155.8	19.6	142.9	144.4	168.3	211.1	230.2	22	38.1	60.3	1.5
120	254.0	186.6	155.8	19.6	142.9	144.4	168.3	211.1	230.2	22	38.1	60.3	1.5
125	254.0	186.6	155.8	19.6	149.2	150.7	168.3	211.1	230.2	22	38.1	60.3	1.5

Seal sizes from 130mm to 300mm are designed to suit specific equipment using modular components. Contact AESSEAL® technical department for dimensional information and availability.

† = F Min + K Max

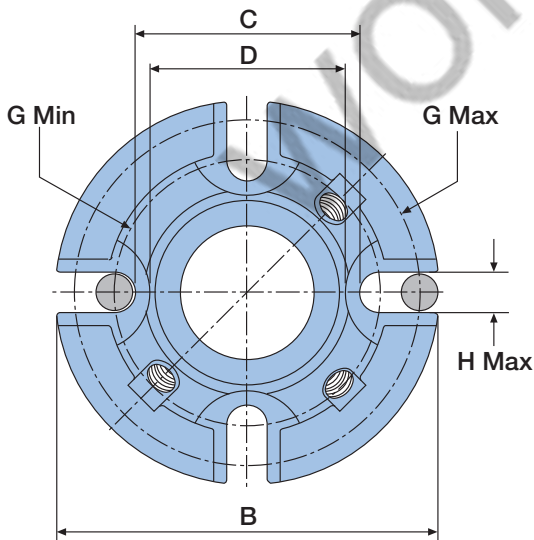

See previous pages for support systems available.



# ANSI+ CSM™ and CDM™- gland designs to suit ANSI+ pumps

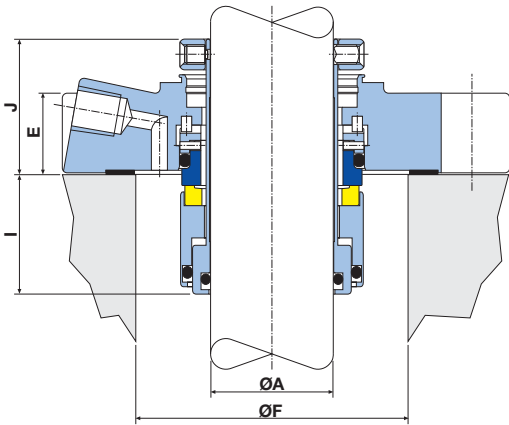

**ANSI+ CSM™ - ANSI+ Gland format Dimensional Information (inches)**

A	B	C	E	F min	F max	G min	G max	H max	I	J	L	K max
1.125	5.000	3.188	1.000	2.625	2.850	3.750	4.250	0.500	1.125	1.565	3.990	0.040
1.375	5.375	3.438	1.000	2.875	3.100	4.000	4.625	0.500	1.125	1.565	4.240	0.040
1.750	6.750	4.438	0.644	3.500	4.100	5.000	6.000	0.500	1.125	1.690	5.480	0.040
1.875	6.750	4.438	0.644	3.625	4.100	5.000	6.000	0.500	1.125	1.690	5.480	0.040
2.125	7.625	4.688	0.644	3.875	4.225	5.375	6.687	0.625	1.250	1.690	6.230	0.040
2.500	8.250	5.438	0.644	4.500	5.100	6.125	7.312	0.625	1.300	1.890	6.730	0.060
2.625	8.250	5.438	0.644	4.625	5.100	6.125	7.312	0.625	1.300	1.890	6.730	0.060
2.750	8.250	5.438	0.644	4.625	5.100	6.125	7.312	0.625	1.300	1.890	6.730	0.060

Minimum bolt circle based on bolt size shown.

The CSM™ and CDM™ range of single and double mechanical seals are available with ANSI+ size gland designs in order to fit ANSI+ equipment.

For any more information on these seals please contact the AESSEAL® Technical Department.

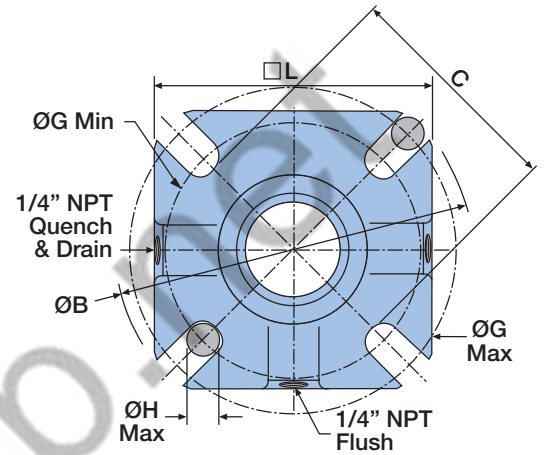
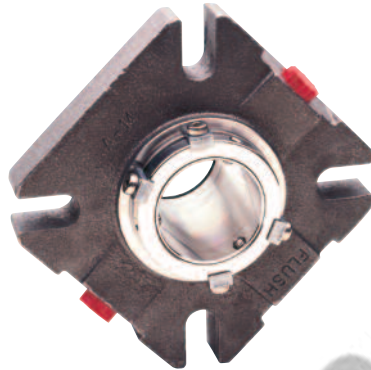

K Max = Maximum TOTAL Radial Movement

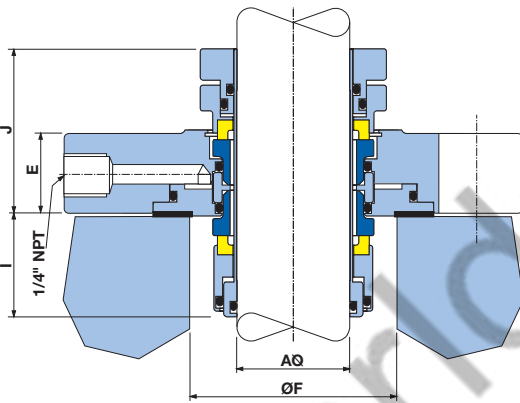
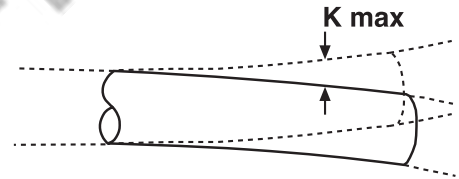

**ANSI+ CDM™ - ANSI+ Gland format Dimensional Information (inches)**

A	B	C	E	F Min	F Max	G Min	G Max	H Max	I	J	L	K max
1.125	5.000	3.188	1.000	2.625	2.850	3.750	4.250	0.500	1.250	2.000	3.990	0.040
1.375	5.375	3.438	1.000	2.875	3.100	4.000	4.625	0.500	1.250	2.000	4.240	0.040
1.750	6.750	4.438	0.644	3.500	4.100	5.000	6.000	0.500	1.350	2.000	5.480	0.040
1.875	6.750	4.438	0.644	3.625	4.100	5.000	6.000	0.500	1.350	2.000	5.480	0.040
2.125	7.625	4.688	0.644	3.875	4.225	5.375	6.687	0.625	1.437	2.000	6.230	0.040
2.500	8.250	5.438	0.644	4.500	5.100	6.125	7.312	0.625	1.500	2.187	6.730	0.060
2.625	8.250	5.438	0.644	4.625	5.100	6.125	7.312	0.625	1.500	2.187	6.730	0.060
2.750	8.250	5.438	0.644	4.625	5.100	6.125	7.312	0.625	1.500	2.187	6.730	0.060

Minimum bolt circle based on bolt size shown.

THIS DOCUMENT IS DESIGNED TO PROVIDE DIMENSIONAL INFORMATION AND AN INDICATION OF AVAILABILITY. FOR FURTHER INFORMATION AND SAFE OPERATING LIMITS CONTACT OUR TECHNICAL SPECIALISTS AT THE LOCATIONS BELOW.



**USE DOUBLE MECHANICAL SEALS WITH HAZARDOUS PRODUCTS. ALWAYS TAKE SAFETY PRECAUTIONS:**

- GUARD YOUR EQUIPMENT
- WEAR PROTECTIVE CLOTHING



**UK Sales & Technical advice:**

AESSEAL plc  
Mill Close  
Templeborough  
Rotherham  
S60 1BZ  
United Kingdom



**INVESTOR IN PEOPLE**

Telephone: +44 (0) 1709 369966  
Fax: +44 (0) 1709 720788  
E-mail: seals@aes seal.com  
Internet: http://www.aes seal.com

Distributed by:

**Our Purpose:** *'To give our customers such exceptional service that they need never consider alternative sources of supply.'*

**USA Sales & Technical advice:**

AESSEAL Inc.  
355 Dunavant Drive  
Rockford,  
TN. 37853  
USA

Telephone: +1 865 531 0192  
Fax: +1 865 531 0571  
E-mail: usa@aes seal.com

ALL SIZES ARE SUBJECT TO MANUFACTURING TOLERANCES. WE RESERVE THE RIGHT TO MODIFY SPECIFICATIONS AT ANY TIME.

AESSEAL plc recognise all trademarks and trademark names as the property of their owners.

ESM™, NCM™, ESTM™, ESCM™, Buffer Canister™, ESCTM™, CSM™, CDM™, CSWIB™, Mixmaster I™, DSWIB™, Mixmaster II™, AES15™, Buffer Reservoir™, PUMPPAC™, FlowTrue™ and SWFF-TF™ are Trademarks of AESSEAL plc  
Registered Trademarks: AESSEAL® - AESSEAL plc

Reference Issue • L-UK/US-MIXERBASIC-06b