

SMART TRACK[®]

Designed to track and maintain a constant differential with fluctuations in process pressure



Features

- Self regulating
- Quick response
- Simplicity
- Factory set
- Ergonomic

Benefits

- Tracks pressure to maintain an optimum double seal environment
- Transient and upset conditions handled with ease
- A compact alternative to complex seals & systems
- No operator intervention required. Unit is supplied pre-set
- Simple in line connections and mounting



SMART TRACK®

Designed to track and maintain a constant differential with fluctuations in process pressure.

Patent pending isolating pressure tracking valve that will maintain a positive differential pressure between a reference input pressure (seal chamber / vessel pressure) and an output pressure (typically API Plan 53A) with the connection of a suitable supply (Typically nitrogen at a pressure greater than maximum operating barrier pressure). The device has an integrated isolation unit that will provide a physical barrier between product (seal chamber / vessel fluid) and the device.

Smart Track® Typical Application

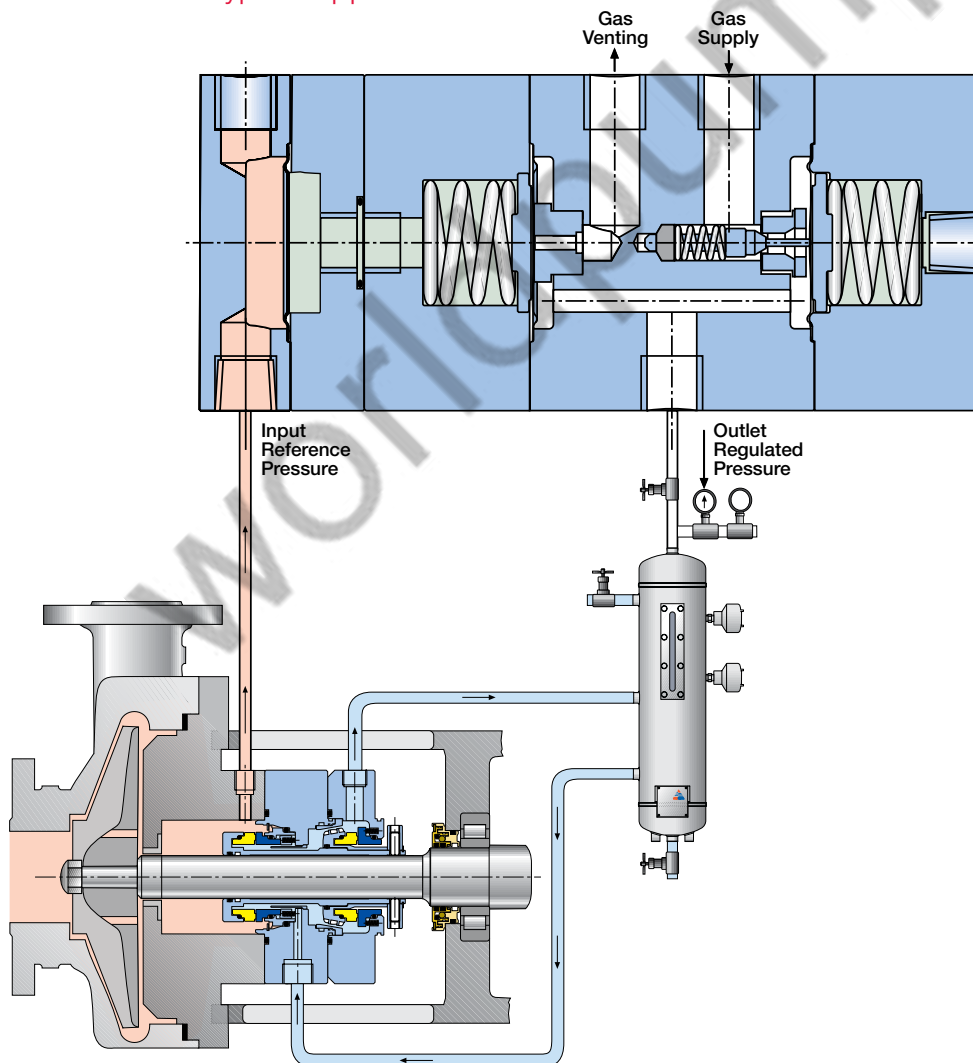

A unique & simple solution designed to maximize mechanical seal reliability through optimized barrier fluid pressure control.

Specifications

Typical Duties:

- Double Seal Barrier fluid support systems
- Seal Chamber pressures from -1 barg to 42 barg (-14.5 to 415 psig)
- Valve temperatures 4° to 80°C (39° to 176°F)
- Operating pressure differential circa 2 bar (30 psi) or circa 4 bar (60 psi)
- Size: L 6.9" (175mm) x Ø3.0" (75mm)
- Connections: Supply, Output, Vent, Reference I/P = ¼ NPT
- Weight: 5.5Kg (12.2lb)
- Mounting: 2 x M8 (Orientated 90° to Ports)

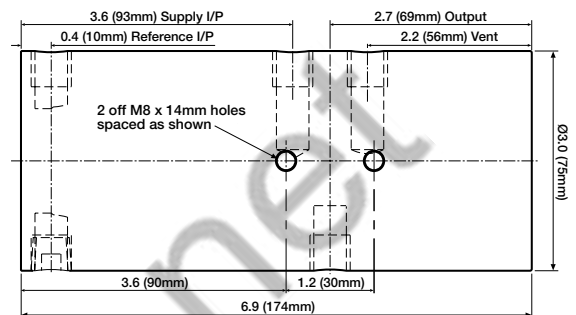

Wetted Materials:

- Diaphragm: Alloy X750
- Bias Spring: 316 Stainless Steel
- Body, End Caps etc: 316L Stainless Steel
- Isolator: 316 Stainless Steel
- Isolator transfer fluid: Ethylene Glycol other fluids are available

Key Features:

- Rapid response to changes in input reference (seal chamber) pressure
- Dynamic Pressure differential maintained during rapid pressure transients
- Integrated isolation unit
- Minimal external connections
- Capable of operating in vacuum conditions

Technical Data:

Supply Inlet Pressure Max: 46 barg (675 psig)

Reference (Seal Chamber / Vessel) Max: 42 barg (615 psig)

Pressure differential transients (Reference to Output): 1– 8 bar (14.5 – 120 psi)

Maximum rate of input pressure change: 13 bar/s (190 psi/s)*

Supply consumption: Application dependent consult AESSEAL® technical department



* Pressurised system volume of 10 Litre (2.64 Gallon US) @ 20°C (68°F), nominal 2 bar (30 psi) differential.





EXPERIENCE THE EXCEPTIONAL

To experience the exceptional, please contact your local representative. Discover full details on our website:

www.aesseal.com

This brochure is fully recyclable. When laminated, a sustainable, biodegradable and recyclable lamination is used.

For further information and safe operating limits contact our technical specialists at the locations below.



AESSEAL plc is certified to ISO 9001, ISO 14001, ISO/IEC 20000, ISO/IEC 27001, ISO/TS 29001, ISO 37001, ISO 45001 & ISO 50001

Use double mechanical seals with hazardous products.

Always take safety precautions:

- Guard your equipment
- Wear protective clothing

WARNING

UK Sales & Technical advice:

AESSEAL plc
 Mill Close
 Bradmarsh Business Park
 Rotherham, S60 1BZ, UK
 Tel: +44 (0) 1709 369966
 Fax: +44 (0) 1709 720788
 E-mail: enquiries@aesseeal.info
www.aesseal.com

'Our purpose is to give our customers such exceptional service that they need never consider alternative sources of supply.'

USA Sales & Technical advice:

AESSEAL Inc.
 355 Dunavant Drive
 Rockford,
 TN. 37853, USA
 Tel: +1 865 531 0192
 Fax: +1 865 531 0571
 E-mail: usa@aesseeal.com
www.aesseal.com

Important: Since the conditions and methods of use of this product are beyond our control, AESSEAL plc expressly disclaims any and all liability resulting or arising from any use of this product or reliance on any information contained in this document - AESSEAL plc standard conditions of sale apply. All sizes are subject to manufacturing tolerances. We reserve the right to modify specifications at any time. AESSEAL® is a Registered Trademark of AES Engineering Ltd, AESSEAL plc recognizes all trademarks and trademark names as the property of their owners.