

DISP™ & SISS™

Double and Single Stationary Seal Range



- Stationary seal face technology to accommodate angular shaft to housing misalignment
- Bi-directional flow induction for effective barrier heat removal (dual seal only)
- Patented anti-shattering seal face technology drive mechanisms
- Modular design for enhanced customer service

“ Ineffective heat removal within the barrier fluid is estimated to account for over 40% of all double cartridge seal failures. ”

DISP™ and SISS™ — 21st Century Innovation

AESSEAL® is a leading global specialist in the design and manufacture of mechanical seals, bearing protectors and seal support systems.

The company sets new standards in reliability, performance, service and cost. Service has been the key to the success of AESSEAL® and is at the core of the company purpose statement — ‘to give our customers such exceptional service that they need never consider alternative sources of supply.’ Through continuous investment, unique modular technology and an unparalleled dedication to customer service we aim to constantly exceed expectation.

Industry leading modular design is proven to decrease costs and increase equipment uptime.

The DISP™ and SISS™ double and single stationary cartridge seal ranges provide highly technical, value-engineered sealing solutions applicable for all industry sectors.

Ineffective heat removal within the barrier fluid is estimated to account for over 40% of all double cartridge seal failures. Hot seal faces = poor seal life. The DISP™ double seal features a highly effective bi-directional flow inducer with a ‘heat removal’ flow path to directly combat this issue.

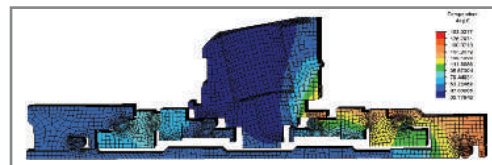

The DISP™ and SISS™ are part of the AESSEAL® modular sealing system. This, combined with extensive inventory levels, ensures that **any** standard seal in any size or material combination is available for immediate despatch. This means you can get an application specific seal quickly and therefore hold less inventory.

AESSEAL Global Technology Centre



Extensive AESSEAL® test facilities





Design, manufacturing and testing at the AESSEAL Global Technology Centre

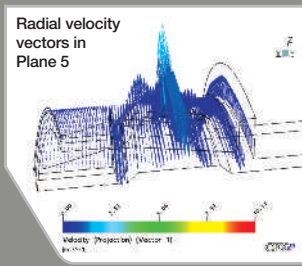

3D CFD vector flow analysis

DISP™ and SISS™ — 21st Century Innovation

The DISP™ and SISS™ product ranges have been developed using the latest, fully integrated software packages. The result is a time-compressed product development period based on a ‘right-first-time’ philosophy.

AESSEAL® employed Computational Fluid Dynamic (CFD) analysis to assess and optimize the seal face heat removal efficiency of the barrier fluid flow path within the DISP™ seal. This analysis, backed by practical testing, facilitated the removal of standing vortices within the barrier chamber. Such standing vortices can lead to hot zones causing thermal cracking and premature seal failure.

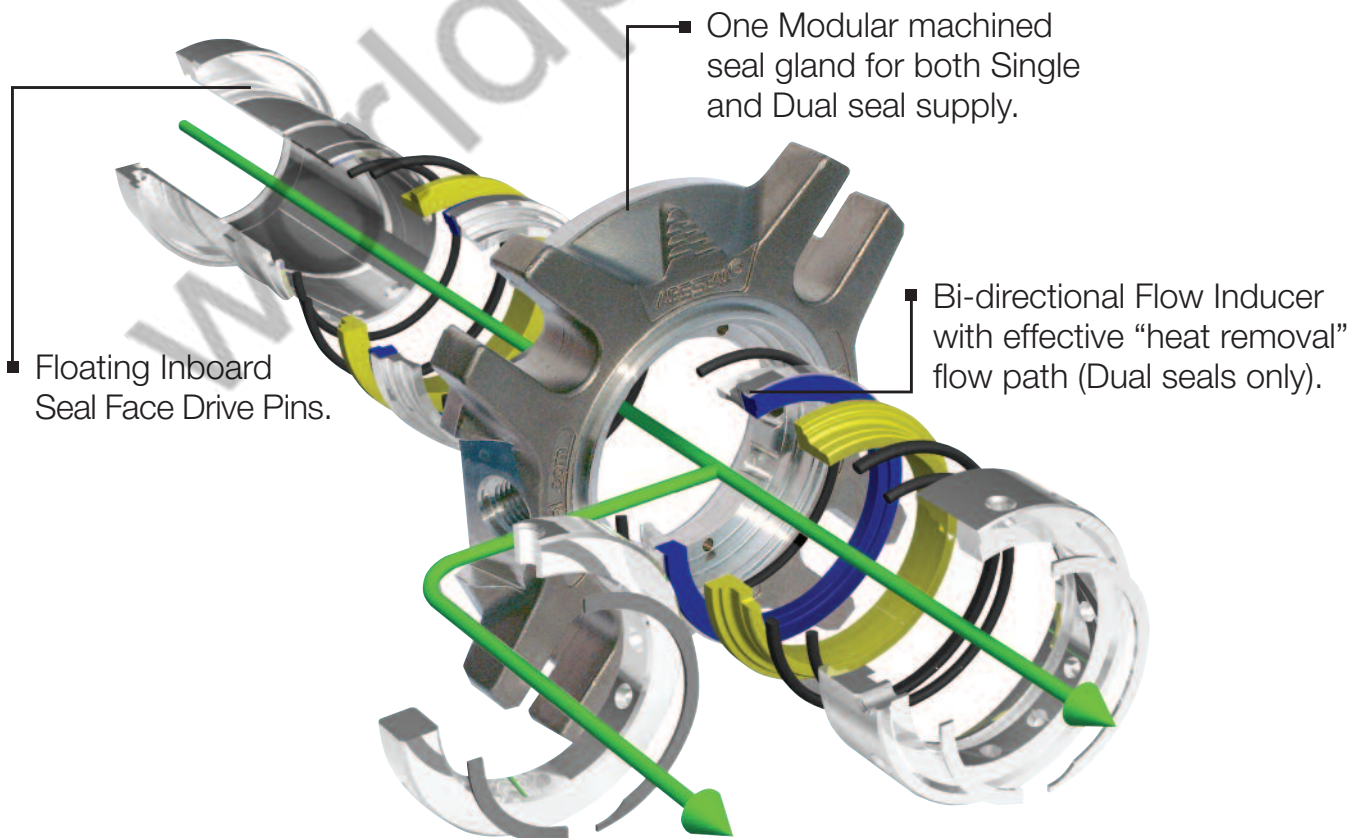



Design Features and Customer Benefits

DISPTM — Double Stationary Seal with Flow Inducer

Dual seal with inboard reverse hydraulic balanced seal faces

The seal faces will remain closed in process upset conditions or in times of lost barrier fluid pressure.

The dual seal has a radially 'thin' inboard seal face running track

Lower heat generation compared with alternate dual balanced seal face designs.

Hydraulically pressure balanced seal faces

Elimination of cantilever forces and thrust loads, which can lead to seal face distortion and leakage.

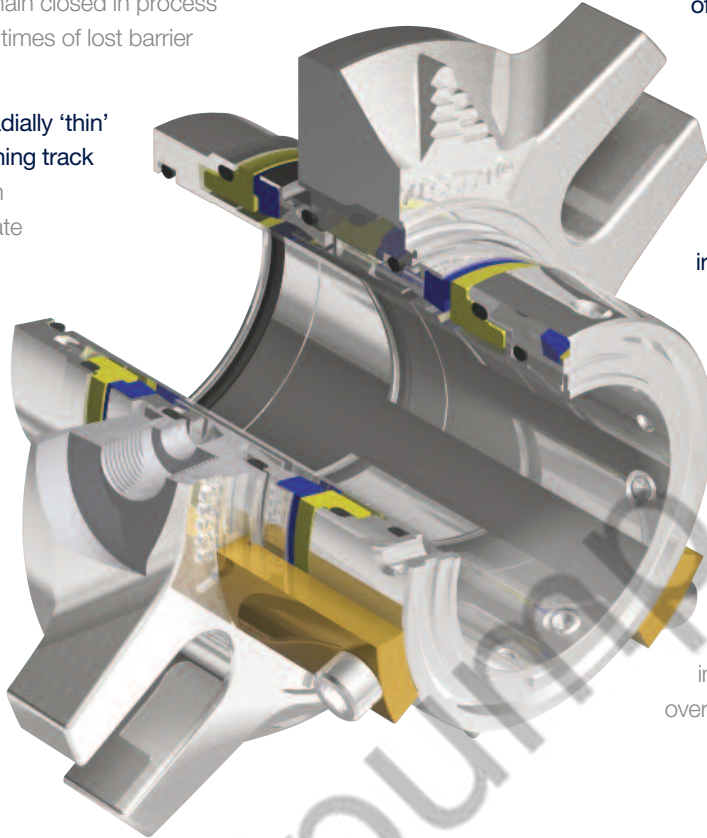

True double mechanical seal with two sets of independent springs

A 'safe' double seal design. The inboard seal faces are not energized by the same springs that energize the outboard seal faces.

Dual seal with bi-directional pumping to circulate barrier fluid irrespective of shaft rotational direction

Effective circulation of the barrier fluid to remove heat build-up within the seal.

One seal design may be employed for double-ended pumps with no risk of operator installation mix-up.

Effective barrier fluid flow path, irrespective of shaft rotation

More reliable heat removal and improved conditions at the seal faces over convection principles.

DISPTM — Pumping Performance

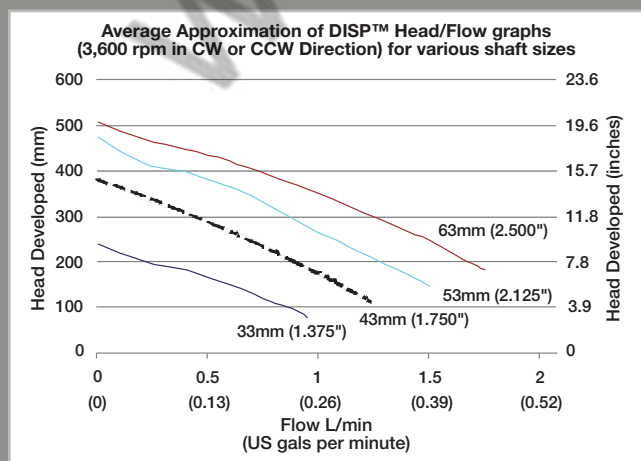

Tests prove that there is an increase in seal performance using a seal with flow induced pumping. The advanced design of the DISPTM / SISS™ flow inducer provides increased barrier flow throughout the seal which removes internal heat.

This allows the seal to work in higher speed and higher temperature applications. The test results shown to the right compare the temperature difference between the inlet and outlet barrier fluid pipes of a conventional style double seat versus a DISPTM design.

In summary the higher the temperature difference, the longer the retention of hot fluid in the barrier cavity.

Cool fluid in the barrier cavity = increased seal life

SISS™ and SISR™ — Single Stationary Seals

Modular Single and Dual seal gland, supplied with Quench, Flush and Drain ports as standard

Increased customer service levels from a finite level of inventory.

Repair Centre benefits from minimum customer inventory holding. Optimize and control the application's environment.

Modular Stationary and Rotary Seal faces

Increased manufacturing economies of scale, lower cost prices leading to a better value for money product.

Centroidally loaded, shrink fitted stationaries

Improved performance in temperature applications with excellent metal to metal drive integrity.

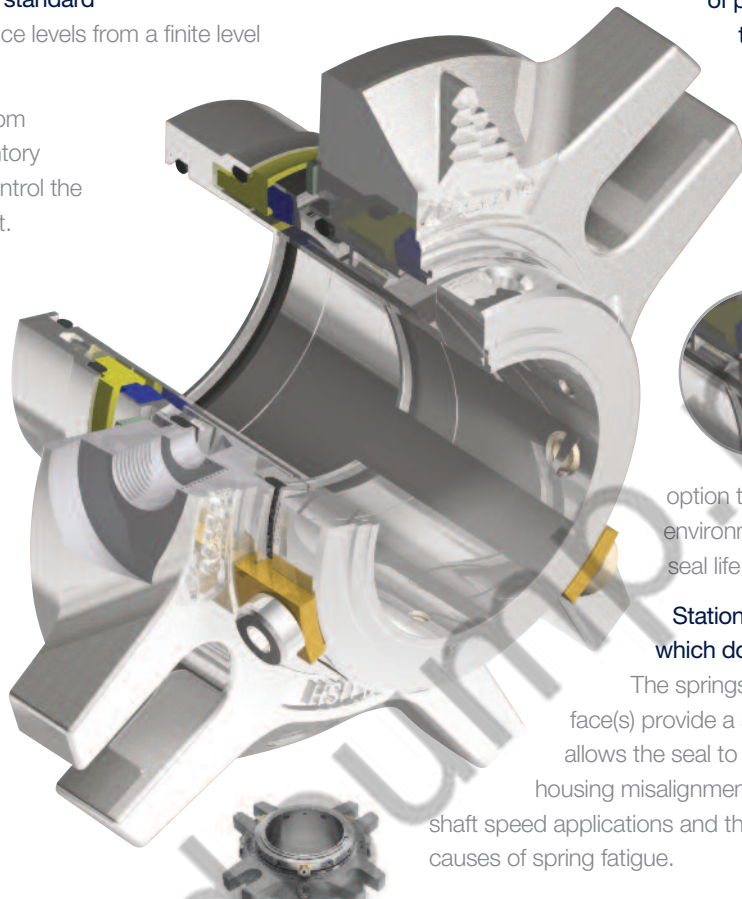

Seal faces are driven by a combination of patented floating seal face drive technology and solid, integral machined drive lugs

Robust, premium seal face drive integrity.

Less seal face breakage.

Longer seal face running life.

Optional, modular restriction-bush for the single seal (SISR™)

The SISR™ offers the Plan 62 standard

option thereby controlling the seal environment and maximizing single seal life.

Stationary seal design with springs, which do not rotate with the shaft

The springs behind the stationary seal face(s) provide a self-aligning feature, which allows the seal to accept some angular shaft to housing misalignment. Excellent design for high shaft speed applications and the elimination of the major causes of spring fatigue.

DISP™ — Why is Effective Pumping Important?

Successful mechanical seal operation is all about controlling the environment at the seal faces. High seal face temperature means fluid film vapourisation, thermal distortion and accelerated seal face deterioration.

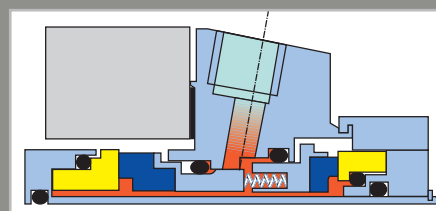
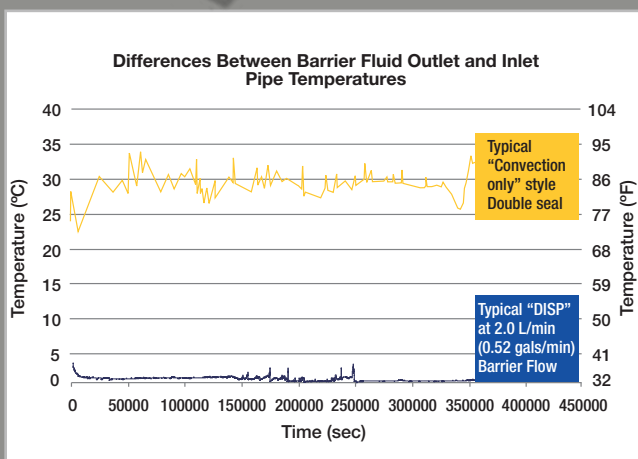

Typical 'convection only' double seal without flow inducer

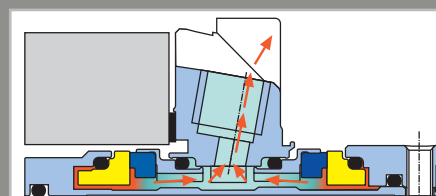

Typical DISP™ mechanical seal with 2.0 L/min (0.52 gals/min) barrier flow



DISP™ – Dimensional Information

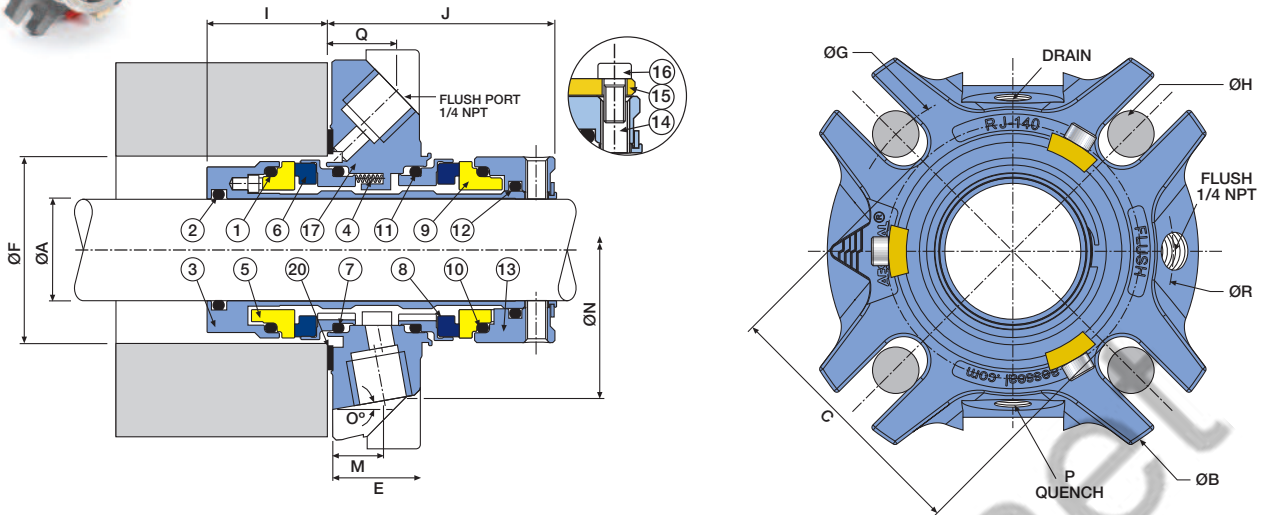

DISP™ – Dimensional Information (mm)

A	B	C	D	E	ØF Min	F Max	ØG Min	ØG Max	ØH Max	I	J	M	N	O	P	Q	R
24	104.8	57.2	-	23.8	41.0	48.6	71.2	92.8	12	28.2	52.6	15.0	71.4	10	1/4NPT	17.9	79.1
25	104.8	57.2	-	23.8	41.0	48.6	71.2	92.8	12	28.2	52.6	15.0	71.4	10	1/4NPT	17.9	79.1
28	108.0	60.4	-	23.8	44.0	52.6	74.3	96.0	12	28.2	52.6	14.1	76.2	10	1/4NPT	17.0	82.6
30	111.1	63.5	-	23.8	46.0	54.7	77.5	99.0	12	28.2	52.6	13.0	78.0	10	1/4NPT	17.8	84.1
32	111.1	63.5	-	23.8	48.0	54.7	77.5	99.0	12	28.2	52.6	13.0	78.5	10	1/4NPT	17.8	84.1
33	111.1	63.5	-	23.8	49.0	54.7	77.5	99.0	12	28.2	52.6	13.0	78.5	10	1/4NPT	17.8	84.1
33K	98.5	63.5	-	21.7	49.0	54.7	77.5	86.5	12	27.5	53.3	13.7	82.6	15	1/4NPT	13.7	90.7
35	111.1	66.7	-	23.8	51.0	58.6	80.7	99.0	12	28.2	52.6	13.0	78.5	10	1/4NPT	17.6	83.8
38	127.0	72.0	-	21.7	58.0	63.6	85.9	115.0	12	28.0	53.3	12.7	85.7	10	1/4NPT	16.2	92.1
40	127.0	72.0	-	21.7	60.0	64.7	85.9	115.0	12	28.0	53.3	12.7	85.7	10	1/4NPT	16.2	92.1
43	133.4	76.8	-	21.7	63.0	68.6	90.8	121.3	12	28.0	53.3	13.0	89.7	10	1/4NPT	16.1	94.9
43K	119.7	81.0	-	17.1	63.0	71.7	95.0	107.6	12	28.0	53.3	22.9	93.5	10	1/4NPT	18.9	101.6
45	133.4	76.8	-	21.7	65.0	70.2	90.8	121.4	12	28.0	53.3	12.7	88.9	10	1/4NPT	16.1	95.3
48	133.4	76.8	-	21.7	67.0	70.2	90.8	121.4	12	28.0	53.3	12.7	88.9	10	1/4NPT	16.2	95.3
50	139.7	86.0	-	21.7	70.0	77.7	100.0	127.7	12	28.0	53.3	12.7	95.3	10	1/4NPT	16.2	101.6
53	146.1	93.6	-	21.7	73.0	84.7	111.1	130.0	16	28.0	53.3	13.4	101.3	10	1/4NPT	16.2	108.0
55	146.1	93.6	-	21.7	75.0	84.7	111.1	130.0	16	28.0	53.3	13.4	101.3	10	1/4NPT	16.2	108.0
58	146.1	93.6	-	21.7	78.0	84.7	111.1	130.0	16	28.0	53.3	13.4	101.3	10	1/4NPT	16.2	108.0
60	152.4	100.0	-	21.7	80.0	89.6	117.5	136.4	16	28.0	53.3	13.7	104.4	10	1/4NPT	16.2	114.3
63	177.8	109.5	-	23.9	82.6	98.6	127.0	161.8	16	27.5	53.9	13.5	121.2	10	3/8NPT	18.8	126.8
65	177.8	109.5	-	23.9	85.7	98.7	127.0	161.8	16	27.5	53.9	13.5	121.2	10	3/8NPT	18.8	126.8
70	177.8	109.5	-	23.9	90.0	99.7	127.0	161.8	16	27.5	53.9	13.5	121.2	10	3/8NPT	18.8	126.8
75	190.5	125.4	-	23.9	98.4	113.5	142.9	174.5	16	33.0	60.2	13.8	130.6	10	3/8NPT	18.5	137.2
80	190.5	125.4	-	23.9	101.6	113.5	142.9	174.5	16	33.0	60.2	13.8	130.6	10	3/8NPT	18.0	138.1
85	203.2	135.0	-	23.9	108.0	121.5	156.0	185.0	20	33.0	60.2	13.4	140.2	10	3/8NPT	18.9	146.0

Note:- The 33K and 43K gland designs are specifically designed to suit the KSB CPK pump with Quench and Drain connections at different angular positions.

DISP™ – Dimensional Information (inches)

A	B	C	D	E	ØF Min	F Max	ØG Min	ØG Max	ØH Max	I	J	M	N	O	P	Q	R
1.000	4.125	2.250	-	0.937	1.625	1.937	2.812	3.625	0.500	1.110	2.070	0.590	2.812	10	1/4NPT	0.705	3.115
1.125	4.250	2.375	-	0.937	1.750	2.093	2.937	3.750	0.500	1.110	2.070	0.550	3.000	10	1/4NPT	0.670	3.250
1.250	4.375	2.500	-	0.937	1.875	2.154	3.062	3.875	0.500	1.110	2.070	0.511	3.090	10	1/4NPT	0.700	3.312
1.375	4.375	2.625	-	0.937	2.000	2.308	3.187	3.875	0.500	1.110	2.070	0.511	3.090	10	1/4NPT	0.693	3.300
1.500	5.000	2.832	-	0.854	2.250	2.500	3.375	4.500	0.500	1.103	2.099	0.500	3.375	10	1/4NPT	0.638	3.625
1.625	2.250	3.022	-	0.854	2.500	2.700	3.562	4.750	0.500	1.103	2.099	0.500	3.532	10	1/4NPT	0.634	3.737
1.750	5.250	3.022	-	0.854	2.500	2.750	3.562	4.750	0.500	1.103	2.099	0.500	3.500	10	1/4NPT	0.634	3.750
1.875	5.250	3.022	-	0.854	2.625	2.750	3.562	4.750	0.500	1.103	2.099	0.500	3.500	10	1/4NPT	0.638	3.750
2.000	5.500	3.386	-	0.854	2.750	3.062	3.937	5.000	0.500	1.103	2.099	0.500	3.750	10	1/4NPT	0.638	4.000
2.125	5.750	3.687	-	0.854	2.875	3.375	4.375	5.125	0.625	1.103	2.099	0.528	3.989	10	1/4NPT	0.638	4.250
2.250	5.750	3.687	-	0.854	3.000	3.375	4.375	5.125	0.625	1.103	2.099	0.528	3.989	10	1/4NPT	0.638	4.250
2.375	6.000	3.937	-	0.854	3.125	3.500	4.625	5.375	0.625	1.103	2.099	0.540	4.111	10	1/4NPT	0.638	4.500
2.500	7.000	4.312	-	0.942	3.250	3.875	5.000	6.375	0.625	1.083	2.125	0.532	4.772	10	3/8NPT	0.741	4.993
2.625	7.000	4.312	-	0.942	3.375	3.875	5.000	6.375	0.625	1.083	2.125	0.532	4.772	10	3/8NPT	0.741	4.993
2.750	7.000	4.312	-	0.942	3.625	3.937	5.000	6.375	0.625	1.083	2.125	0.532	4.772	10	3/8NPT	0.741	4.993
2.875	7.500	4.937	-	0.942	3.750	4.437	5.625	6.625	0.625	1.300	2.375	0.545	5.140	10	3/8NPT	0.741	5.375
3.000	7.500	4.937	-	0.942	3.875	4.500	5.625	6.875	0.625	1.300	2.375	0.545	5.142	10	3/8NPT	0.728	5.402
3.125	7.500	4.937	-	0.942	4.000	4.500	5.625	6.875	0.625	1.300	2.375	0.545	5.142	10	3/8NPT	0.709	5.438
3.250	8.000	5.312	-	0.942	4.125	4.750	6.125	7.250	0.750	1.300	2.375	0.528	5.520	10	3/8NPT	0.744	5.750
3.375	8.000	5.312	-	0.942	4.250	4.750	6.125	7.250	0.750	1.300	2.375	0.528	5.520	10	3/8NPT	0.744	5.750

Item	Description	Material	Item	Description	Material
1	Rotary O Ring	Viton® / EPR / Kalrez® / Aflas®	11	Outer Stationary O Ring	Viton® / EPR / Kalrez® / Aflas®
2	Sleeve O Ring	Viton® / EPR / Kalrez® / Aflas®	12	Clamp Ring O Ring	Viton® / EPR / Kalrez® / Aflas®
3	Sleeve	316L Stainless Steel	13	Clamp Ring	316L Stainless Steel
4	Springs	Alloy 276	14	Anti-Tamper Screw	316 Stainless Steel
5	Inner Rotary Face	SiC	15	Setting Clips	Brass
6	Inner Stationary Face	316L SS - Carbon / SiC	16	Clip Screws	316 Stainless Steel
7	Stationary O Ring	Viton® / EPR / Kalrez® / Aflas®	17	Gland	316 Stainless Steel
8	Outer Stationary Face	316L SS - Carbon / SiC	18	Drive Screws	316 Stainless Steel
9	Outer Rotary Face	SiC	19	Springs (not shown)	Alloy 276
10	Outer Rotary O Ring	Viton® / EPR / Kalrez® / Aflas®	20	Gasket	AF1 / GFT



SISS™ and SISR™ – Dimensional Information

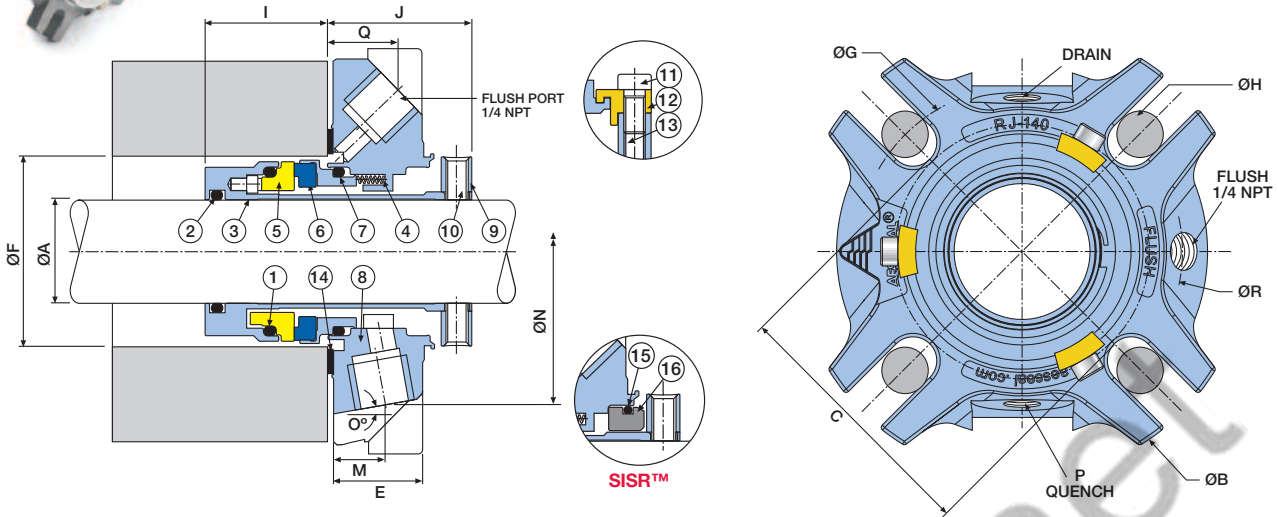

SISS™ — Dimensional Information (mm)

A	B	C	D	E	ØF Min	F Max	ØG Min	ØG Max	ØH Max	I	J	M	N	O	P	Q	R
24	104.8	57.2	-	23.8	41.0	48.6	71.2	92.8	12	28.2	38.3	15.0	71.4	10	1/4NPT	17.9	79.1
25	104.8	57.2	-	23.8	41.0	48.6	71.2	92.8	12	28.2	38.3	15.0	71.4	10	1/4NPT	17.9	79.1
28	108.0	60.4	-	23.8	44.0	52.6	74.3	96.0	12	28.2	38.3	14.1	76.2	10	1/4NPT	17.0	82.6
30	111.1	63.5	-	23.8	46.0	54.7	77.5	99.0	12	28.2	38.3	13.0	78.0	10	1/4NPT	17.8	84.1
32	111.1	63.5	-	23.8	48.0	54.7	77.5	99.0	12	28.2	38.3	13.0	78.5	10	1/4NPT	17.8	84.1
33	111.1	63.5	-	23.8	49.0	54.7	77.5	99.0	12	28.2	38.3	13.0	78.5	10	1/4NPT	17.8	84.1
33K	98.5	63.5	-	21.7	49.0	54.7	77.5	86.5	12	27.7	36.8	13.7	82.5	15	1/4NPT	13.7	90.7
35	111.1	66.7	-	23.8	51.0	58.6	80.7	99.0	12	28.2	38.3	13.0	78.5	10	1/4NPT	17.6	83.8
38	127.0	72.0	-	21.7	58.0	63.6	85.9	115.0	12	28.0	36.8	12.7	85.7	10	1/4NPT	16.2	92.1
40	127.0	72.0	-	21.7	60.0	64.7	85.9	115.0	12	28.0	36.8	12.7	85.7	10	1/4NPT	16.2	92.1
43	133.4	76.8	-	21.7	63.0	68.6	90.8	121.3	12	28.0	36.8	13.0	89.7	10	1/4NPT	16.1	94.9
43K	119.7	81.0	-	17.1	63.0	71.7	95.0	107.6	12	28.0	43.8	22.9	93.5	45	1/4NPT	18.9	101.6
45	133.4	76.8	-	21.7	65.0	70.2	90.8	121.4	12	28.0	36.8	12.7	88.9	10	1/4NPT	16.1	95.3
48	133.4	76.8	-	21.7	67.0	70.2	90.8	121.4	12	28.0	36.8	12.7	88.9	10	1/4NPT	16.2	95.3
50	139.7	86.0	-	21.7	70.0	77.7	100.0	127.7	12	28.0	36.8	12.7	95.3	10	1/4NPT	16.2	101.6
53	146.1	93.6	-	21.7	73.0	84.7	111.1	130.0	16	28.0	36.8	13.4	101.3	10	1/4NPT	16.2	108.0
55	146.1	93.6	-	21.7	75.0	84.7	111.1	130.0	16	28.0	36.8	13.4	101.3	10	1/4NPT	16.2	108.0
58	146.1	93.6	-	21.7	78.0	84.7	111.1	130.0	16	28.0	36.8	13.4	101.3	10	1/4NPT	16.2	108.0
60	152.4	100.0	-	21.7	80.0	89.6	117.5	136.4	16	28.0	36.8	13.7	104.4	10	1/4NPT	16.2	114.3
63	177.8	109.5	-	23.9	82.6	98.6	127.0	161.8	16	27.4	39.5	13.5	121.2	10	3/8NPT	18.8	126.8
65	177.8	109.5	-	23.9	85.7	98.7	127.0	161.8	16	27.4	39.5	13.5	121.2	10	3/8NPT	18.8	126.8
70	177.8	109.5	-	23.9	90.0	99.7	127.0	161.8	16	27.4	39.5	13.5	121.2	10	3/8NPT	18.8	126.8
75	190.5	125.4	-	23.9	98.4	113.5	142.9	174.5	16	33.0	39.7	13.8	130.6	10	3/8NPT	18.5	137.2
80	190.5	125.4	-	23.9	101.6	113.5	142.9	174.5	16	33.0	39.7	13.8	130.6	10	3/8NPT	18.0	138.1
85	203.2	135.0	-	23.9	108.0	121.5	156.0	185.0	20	33.0	39.7	13.4	140.2	10	3/8NPT	18.9	146.0

Note: - The 33K and 43K gland designs are specifically designed to suit the KSB CPK pump with Quench and Drain connections at different angular positions.

SISS™ — Dimensional Information (inches)

A	B	C	D	E	ØF Min	F Max	ØG Min	ØG Max	ØH Max	I	J	M	N	O	P	Q	R
1.000	4.125	2.25	-	0.937	1.625	1.937	2.812	3.625	0.500	1.110	1.508	0.590	2.812	10	1/4NPT	0.705	3.115
1.125	4.250	2.375	-	0.937	1.750	2.093	2.937	3.750	0.500	1.110	1.508	0.555	3.000	10	1/4NPT	0.705	3.250
1.250	4.375	2.500	-	0.937	1.875	2.154	3.062	3.875	0.500	1.110	1.508	0.511	3.091	10	1/4NPT	0.700	3.312
1.375	4.375	2.625	-	0.937	2.000	2.308	3.062	3.875	0.500	1.110	1.508	0.511	3.091	10	1/4NPT	0.693	3.300
1.500	5.000	2.832	-	0.854	2.250	2.500	3.375	4.500	0.500	1.103	1.449	0.500	3.375	10	1/4NPT	0.638	3.625
1.625	5.250	3.022	-	0.854	2.375	2.700	3.573	4.750	0.500	1.103	1.449	0.500	3.532	10	1/4NPT	0.638	3.737
1.750	5.250	3.022	-	0.854	2.500	2.750	3.573	4.750	0.500	1.103	1.449	0.500	3.500	10	1/4NPT	0.634	3.750
1.875	5.250	3.022	-	0.854	2.625	2.750	3.573	4.750	0.500	1.103	1.449	0.500	3.500	10	1/4NPT	0.638	3.750
2.000	5.500	3.386	-	0.854	2.750	3.062	3.937	5.000	0.500	1.103	1.449	0.500	3.750	10	1/4NPT	0.638	4.000
2.125	5.750	3.687	-	0.854	2.875	3.375	4.375	5.125	0.625	1.103	1.449	0.528	3.989	10	1/4NPT	0.638	4.250
2.250	5.750	3.687	-	0.854	3.000	3.375	4.375	5.125	0.625	1.103	1.449	0.528	3.989	10	1/4NPT	0.638	4.250
2.375	6.000	3.937	-	0.854	3.125	3.500	4.625	5.375	0.625	1.103	1.449	0.540	4.111	10	1/4NPT	0.638	4.500
2.500	7.000	4.312	-	0.942	3.250	3.875	5.000	6.375	0.625	1.083	1.556	0.532	4.772	10	3/8NPT	0.741	4.993
2.625	7.000	4.312	-	0.942	3.375	3.875	5.000	6.375	0.625	1.083	1.556	0.532	4.772	10	3/8NPT	0.741	4.993
2.750	7.000	4.312	-	0.942	3.625	3.937	5.000	6.375	0.625	1.083	1.556	0.532	4.772	10	3/8NPT	0.741	4.993
2.875	7.500	4.937	-	0.942	3.750	4.437	5.625	6.875	0.625	1.300	1.556	0.545	5.140	10	3/8NPT	0.742	5.375
3.000	7.500	4.937	-	0.942	3.875	4.500	5.625	6.875	0.625	1.300	1.563	0.545	5.142	10	3/8NPT	0.728	5.402
3.125	7.500	4.937	-	0.942	4.000	4.500	5.625	6.875	0.625	1.300	1.563	0.545	5.142	10	3/8NPT	0.709	5.438
3.250	8.000	5.312	-	0.942	4.125	4.750	6.125	7.250	0.750	1.300	1.562	0.528	5.520	10	3/8NPT	0.734	5.750
3.375	8.000	5.312	-	0.942	4.250	4.750	6.125	7.250	0.750	1.300	1.563	0.528	5.520	10	3/8NPT	0.744	5.750

Item	Description	Material	Item	Description	Material
1	Rotary O Ring	Viton® / EPR / Kalrez® / Aflas®	9	Clamp Ring	316L Stainless Steel
2	Sleeve O Ring	Viton® / EPR / Kalrez® / Aflas®	10	Drive Screws	Stainless Steel
3	Sleeve	316L Stainless Steel	11	Clip Screws	Stainless Steel
4	Springs	Alloy 276	12	Setting Clips	Brass
5	Rotary Face	SiC	13	Anti-tamper Screws	Stainless Steel
6	Stationary Face	316L SS - Carbon / SiC	14	Gasket	AF1 / GFT
7	Stationary O Ring	Viton® / EPR / Kalrez® / Aflas®	15	R' Bush O Ring	Viton® / EPR / Kalrez® / Aflas®
8	Gland	316 Stainless Steel	16	Restriction Bushing	Carbon

ANSI+ SISS™ and ANSI+ DISP™

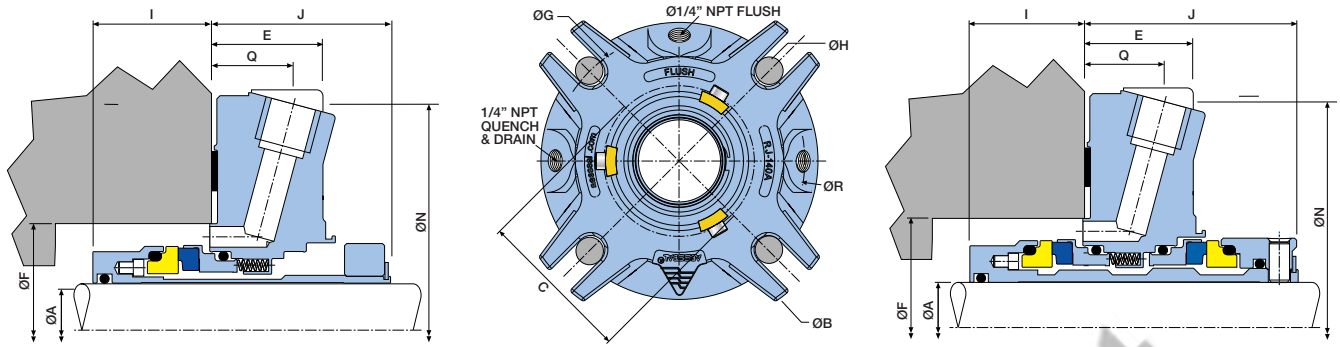

SISS™ ANSI+ Dimensional Information (mm)

A	B	C	E	ØF Min	F Max	ØG Min	ØG Max	ØH Max	I	J	N	Q
1.125	4.975	2.060	0.890	2.625	2.85	3.750	4.450	0.500	1.187	1.437	3.892	0.625
1.375	5.328	2.303	0.890	2.875	3.100	4.000	4.812	0.500	1.187	1.437	4.190	0.640
1.750	6.750	3.035	1.053	3.500	4.100	5.000	6.250	0.500	1.125	1.687	5.276	0.774
1.875	6.750	3.035	1.053	3.625	4.100	5.000	6.250	0.500	1.125	1.687	5.276	0.774
2.125	7.600	3.285	0.920	3.875	4.225	5.375	6.937	0.625	1.210	1.580	6.134	0.666
2.500	8.266	3.910	1.157	4.500	5.100	6.125	7.312	0.625	1.070	1.770	6.614	0.758
2.625	8.266	3.910	1.157	4.625	5.100	6.125	7.312	0.625	1.070	1.770	6.614	0.758

DISP™ ANSI+ Dimensional Information (mm)

A	B	C	E	ØF Min	F Max	ØG Min	ØG Max	ØH Max	I	J	N	Q
1.125	4.975	2.060	0.890	2.625	2.85	3.750	4.450	0.500	1.187	2.000	3.890	0.625
1.375	5.328	2.303	0.890	2.875	3.100	4.000	4.812	0.500	1.187	2.000	4.190	0.640
1.750	6.750	3.035	1.053	3.500	4.100	5.000	6.250	0.500	1.125	2.076	5.276	0.774
1.875	6.750	3.035	1.053	3.625	4.100	5.000	6.250	0.500	1.125	2.076	5.276	0.774
2.125	7.600	3.285	0.920	3.395	4.225	5.375	6.937	0.625	1.210	2.000	6.134	0.666
2.500	8.266	3.910	1.157	4.500	5.100	6.125	7.312	0.625	1.070	2.150	6.614	0.758
2.625	8.266	3.910	1.157	4.625	5.100	6.125	7.312	0.625	1.070	2.150	6.614	0.758

Our purpose is to give our customers such exceptional service that they need never consider alternative sources of supply.

This document is designed to provide dimensional information and an indication of availability. For further information and safe operating limits contact our technical specialists at the locations below.



Use double mechanical seals with hazardous products.

Always take safety precautions:

WARNING

- Guard your equipment
- Wear protective clothing

UK Sales & Technical advice:

AESSEAL plc
Mill Close
Bradmarsh Business Park
Rotherham
S60 1BZ
United Kingdom

Tel: +44 (0) 1709 369966
Fax: +44 (0) 1709 720788
E-mail: seals@aessecal.com

Distributed by:

'Our purpose is to give our customers such exceptional service that they need never consider alternative sources of supply.'

www.aessecal.com

USA Sales & Technical advice:

AESSEAL Inc.
355 Dunavant Drive
Rockford
TN. 37853
USA

Tel: +1 865 531 0192
Fax: +1 865 531 0571
E-mail: usa@aessecal.com

Important: Since the conditions and methods of use of this product are beyond our control, AESSEAL plc expressly disclaims any and all liability resulting or arising from any use of this product or reliance on any information contained in this document - AESSEAL plc standard conditions of sale apply. All sizes are subject to manufacturing tolerances. We reserve the right to modify specifications at any time. AESSEAL® is a Registered Trademark of AESSEAL plc, AESSEAL plc recognizes all trademarks and trademark names as the property of their owners.