

# CURC™

Range of Single Cartridge Mechanical Seals

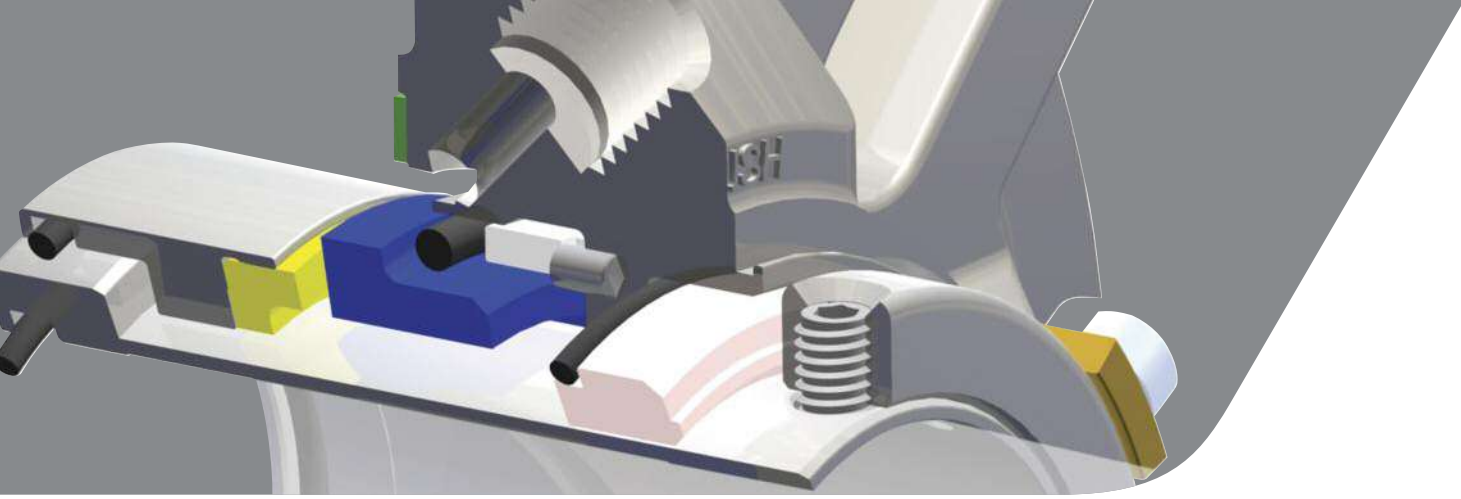

- CRCO™ lip seal option
- CURE™ secondary seal option
- ANSI+ gland options
- Self-aligning faces
- Flush, quench and drain ports



## High Performance Sealing Solution

The AESSEAL CURC™, CRCO™ and CURE™ mechanical seals are part of a range of seals specifically designed to optimize the use of Silicon Carbide.

All these seals incorporate improved third generation self-aligning technology. The design objective was to minimize metal to Silicon Carbide impact, particularly on start-up.

In some seal designs, impact between metal anti-rotation pins and Silicon Carbide can be sufficiently severe to induce stress cracking in the Silicon Carbide.

Silicon Carbide has many advantages when used in mechanical seals. The material has superior chemical resistance, hardness and heat dissipation properties compared to practically any other material used as a mechanical seal face. Silicon Carbide is, however, brittle by nature, so the design of the self-aligning stationary in the CURC™ range of mechanical seals seeks to minimize this metal to Silicon impact on start-up.

### Flexibility

There are seven modular face combinations in the range comprising: Carbon/Ceramic; Carbon/Solid Tungsten Carbide (TC); Carbon/Silicon Carbide (SiC); Carbon/Chrome Oxide and hard face options comprising: TC/TC; TC/SiC and SiC/SiC.

The benefit in the CURC™, CRCO™ and CURE™ design is extended mechanical seal life as the correct face combination can be selected for each individual application.

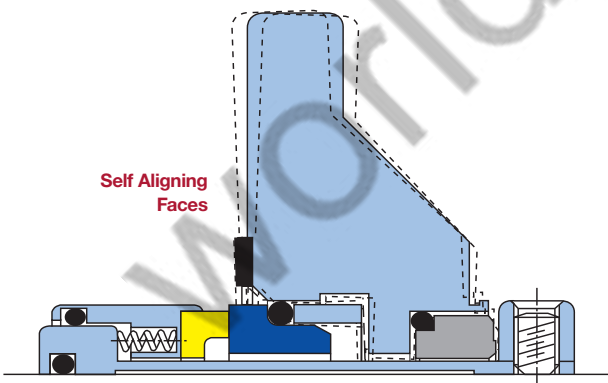

### Self Aligning Faces

The next step in performance maximization is to ensure that the seal faces stay loaded and perpendicular to the axis of the rotating shaft. Insertion of gaskets in imprecise rotating equipment make this requirement critical to long-term seal life.

Self-aligning stationary designs, incorporating a spring loaded rotary and a floating stationary face, address the angular misalignment problem. Building on the success of the “universal joint self-aligning system”, the CURC™, CRCO™ and CURE™ developments incorporate improved third generation self-aligning technology.

### Cartridge Construction

Cartridge seal construction is a proven reliability improvement. Seals pre-assembled at the factory, pressure tested and shipped as a unit dramatically increase performance as errors due to incorrect installation decline. It is no longer necessary to measure and set spring compression as assembled seals mean that faces are protected from damage during installation.

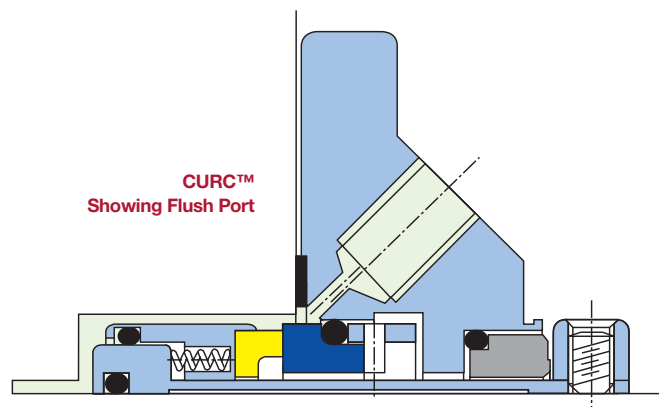

## Design features

### Single Seals with Environmental Control Options

General service applications are efficiently sealed with an 'O' ring mounted, balanced, self-aligning seal. The SAI™, CS™, USI™ and NSI™ component seals and the SCUSI™ and Convertor II™ cartridge seals effectively seal all general service applications.

At the other end of the application spectrum, hazardous and dangerous products demand an engineered sealing approach. Double seals with closed-loop convection tank systems provide the necessary back-up protection.

Between these application extremes lie non-lubricating and/or non-hazardous fluids that alter their state with environmental changes.

A single seal, with an API type gland, provides temperature control and protection from atmospheric contact for these applications.

\*This gland derivation comes from the American Petroleum Institute (API) specification.

Secondary fluids introduced through the Quench and Drain ports to the atmospheric side of the seal faces, control the environment without dilution of the process fluid. Water, steam, grease, oil and other suitable barrier fluids can be used.

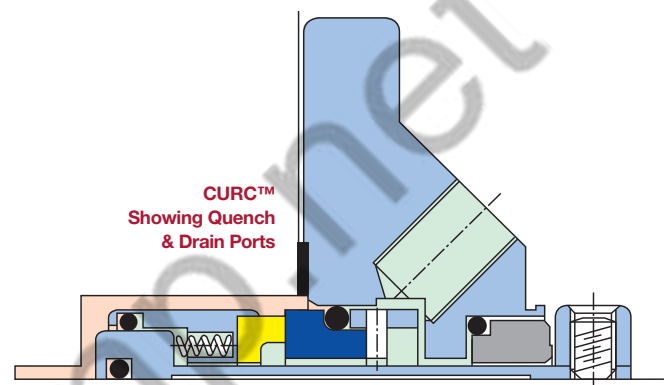
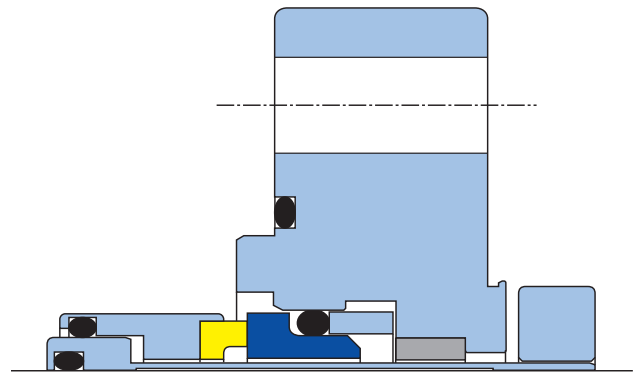

\*A version of the CURC™ can be supplied, with a fully machined gland, which conforms to the dimensional requirements of API 682. These can be used on applications where qualification tested, fully API 682 compliant seals are not required.

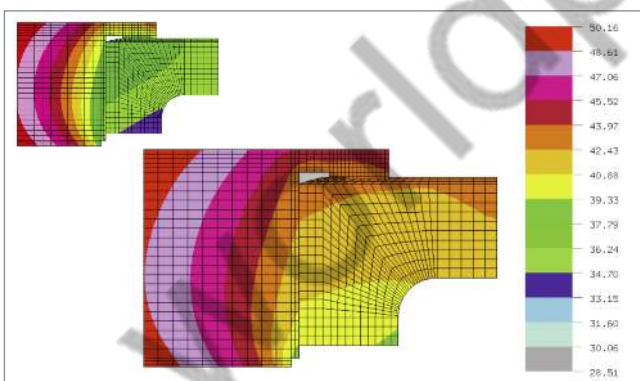

**2D-Axisymmetric Finite Element Analysis review showing flatness of the seal face after shrink fit under different thermal and pressure conditions.**

### Finite Element Analysis and Design

With the aid of Finite Element Analysis (FEA), AESSEAL® designed a "universal joint self-aligning system". Modelling the effects of temperature, pressure and rotational shear stress were just a few of the considerations. A rigid back-up ring with radially mounted pins behind the stationary provides compensation for angular misalignment, offering higher pressure capabilities and optimum protection against anti-rotation pin shear stress. In addition, the spring loaded rotary centrifuges solids away from the seal face and resists clogging, increasing the effectiveness of the seal in slurries and some abrasives. Faces remain flat, square to the shaft and suspended solids are prevented from crossing the flat seal faces.

### AESSEAL® Design and Testing

For every seal developed by AESSEAL®, we use state-of-the-art computational facilities and numerical tools to design and optimize seal performance prior to manufacture and testing.

These tools include Predictive Software Code developed in-house, Finite Element Analysis (FEA) and Computational Fluid Dynamics (CFD). Our numerical tools are used for seal design, performance optimization, special product application and troubleshooting. In combination with an extensive test programme the result is world-leading technology that keeps your equipment running longer.

# CURC™ Range

Sizes available: 1.000" - 5.000" (24mm - 125mm)

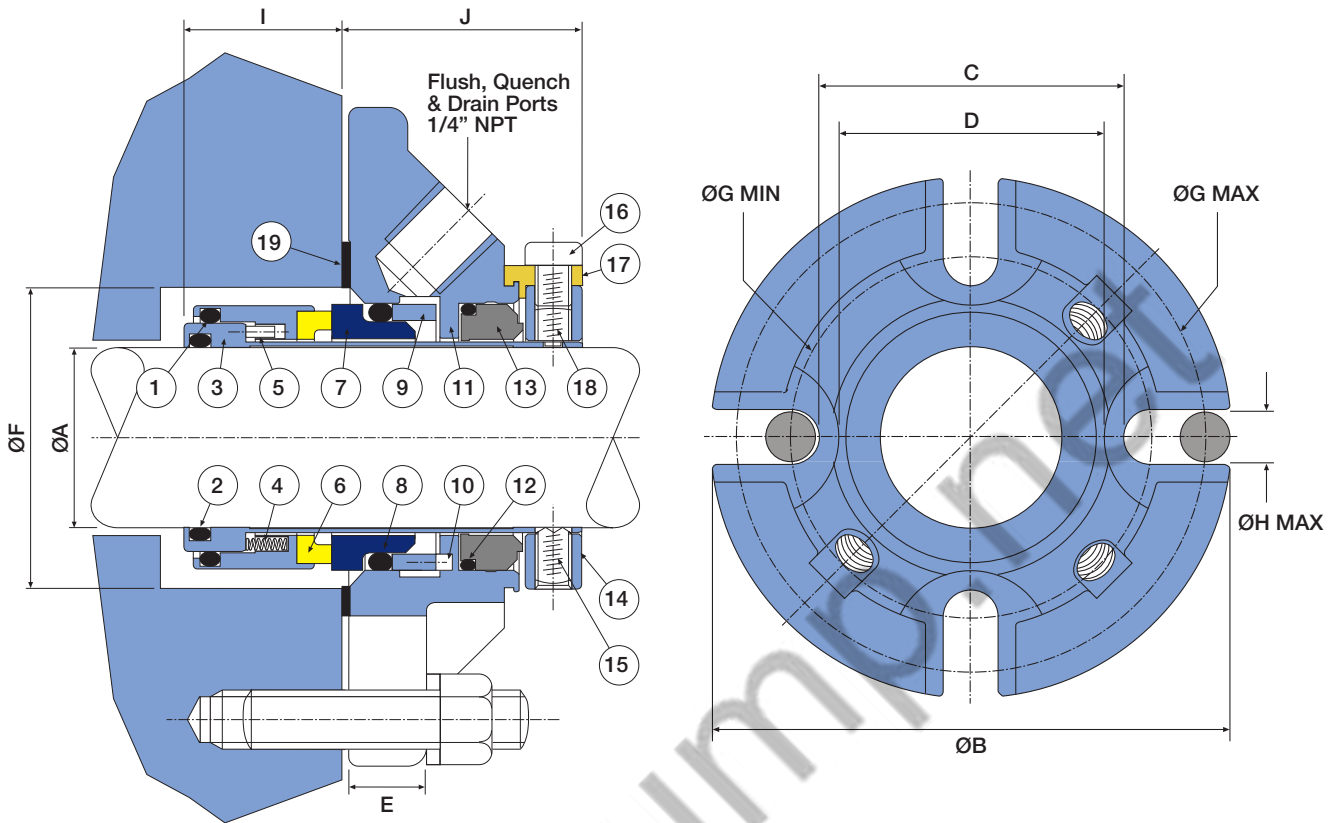

Item	Description	Material	Item	Description	Material
1	Rotary O Ring	Viton® / EPR / Kalrez® / Aflas®	11	Gland	316 Stainless Steel
2	Sleeve O Ring	Viton® / EPR / Kalrez® / Aflas®	12	R'Bush O Ring	Viton® / EPR / Kalrez® / Aflas®
3	Cartridge Sleeve	316L Stainless Steel	13	Restriction Bushing	Carbon
4	Springs	Alloy 276	14	Clamp Ring	316L Stainless Steel
5	Rotating Drive Pins	Stainless Steel	15	Drive Screws	Stainless Steel
6	Rotating Face	316L SS - Carbon / TC / SiC*	16	Clip Screws	Stainless Steel
7	Stationary Face	SiC / Ceramic** / TC	17	Radial Setting Clips	Brass
8	Stationary O Ring	Viton® / EPR / Kalrez® / Aflas®	18	Anti-Tamper Screws	Stainless Steel
9	Universal Pivot Ring	316L Stainless Steel	19	Gasket	AF1 / GFT
10	Gland Pins	Stainless Steel			

CURC™ Range dimensions - 5.125" - 12.000" (130mm - 300mm)

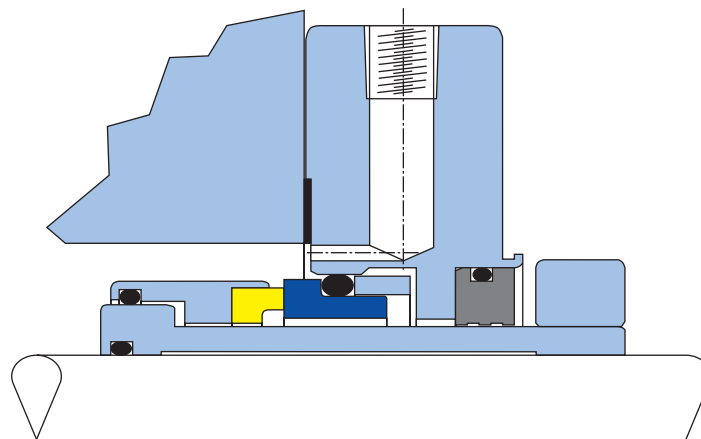

# CURC™ Dimensions

CURC™ Size Chart (inches)

A	B	C	D	E	ØFmin	ØFmax	ØGmin	ØGmax	ØHmax	I	J
1.000	4.125	2.125	1.937	0.519	1.625	1.937	2.687	3.562	1/2	1.125	1.590
1.125	4.250	2.250	2.063	0.519	1.750	2.062	2.812	3.687	1/2	1.125	1.590
1.250	4.375	2.375	2.187	0.519	1.875	2.187	2.937	3.812	1/2	1.125	1.590
1.375	4.375	2.500	2.312	0.519	2.000	2.250	3.062	3.812	1/2	1.125	1.590
1.500	5.000	2.812	2.562	0.644	2.250	2.375	3.375	4.437	1/2	1.125	1.752
1.625	5.000	2.812	2.562	0.644	2.375	2.500	3.375	4.437	1/2	1.125	1.752
1.750	5.500	3.187	2.812	0.644	2.500	2.750	3.750	4.937	1/2	1.125	1.752
1.875	5.500	3.187	2.812	0.644	2.625	2.875	3.750	4.937	1/2	1.125	1.752
2.000	6.000	3.562	3.063	0.644	2.750	3.000	4.125	5.437	1/2	1.125	1.752
2.000-AC	5.250	3.450	3.035	0.644	2.750	3.000	4.000	4.750	1/2	1.125	1.752
2.125	6.000	3.562	3.063	0.644	2.875	3.125	4.125	5.437	1/2	1.125	1.752
2.250	6.500	3.812	3.312	0.644	3.000	3.250	4.500	5.812	5/8	1.125	1.752
2.375	6.500	3.812	3.312	0.644	3.125	3.375	4.500	5.812	5/8	1.125	1.752
2.500	7.000	4.312	3.812	0.769	3.375	3.625	5.000	6.312	5/8	1.250	1.877
2.625	7.000	4.312	3.812	0.769	3.500	3.750	5.000	6.312	5/8	1.250	1.877
2.750	7.000	4.312	3.812	0.769	3.625	3.875	5.000	6.312	5/8	1.250	1.877
2.875	7.500	4.937	4.250	0.769	3.750	4.125	5.625	6.812	5/8	1.250	1.877
3.000	7.500	4.937	4.250	0.769	3.875	4.250	5.625	6.812	5/8	1.250	1.877
3.125	7.500	4.937	4.250	0.769	4.000	4.375	5.625	6.812	5/8	1.250	1.877
3.250	8.000	5.312	4.625	0.769	4.125	4.500	6.125	7.187	3/4	1.250	1.877
3.375	8.000	5.312	4.625	0.769	4.250	4.625	6.125	7.187	3/4	1.250	1.877
3.500	8.000	5.312	4.625	0.769	4.375	4.750	6.125	7.187	3/4	1.250	1.877
3.625	8.500	5.937	5.000	0.769	4.500	5.000	6.750	7.687	3/4	1.250	1.877
3.750	8.500	5.937	5.000	0.769	4.625	5.125	6.750	7.687	3/4	1.250	1.877
3.875	8.500	5.937	5.000	0.769	4.750	5.250	6.750	7.687	3/4	1.250	1.877
4.000	9.000	6.625	5.375	0.769	4.875	5.500	7.437	8.187	3/4	1.250	1.877
4.125	9.000	6.625	5.375	0.769	5.125	5.875	7.437	8.187	3/4	1.250	1.877
4.250	9.000	6.625	5.375	0.769	5.125	5.875	7.437	8.187	3/4	1.250	1.877
4.375	9.500	7.000	5.750	0.769	5.375	5.625	7.812	8.687	3/4	1.250	1.877
4.500	9.500	7.000	5.750	0.769	5.375	6.250	7.812	8.687	3/4	1.250	1.877
4.625	10.000	7.345	6.125	0.769	5.625	6.625	8.312	9.062	7/8	1.250	1.877
4.750	10.000	7.345	6.125	0.769	5.625	6.625	8.312	9.062	7/8	1.250	1.877
4.875	10.000	7.345	6.125	0.769	5.875	6.625	8.312	9.062	7/8	1.250	1.877
5.000	10.000	7.345	6.125	0.769	5.875	6.625	8.312	9.062	7/8	1.250	1.877

Seal sizes from 5.125" to 12.000" are designed to suit specific equipment using modular components.  
 Contact AESSEAL® technical department for dimensional information and availability.

For exotic alloy versions, add 0.125" to seal length inboard

\*Factory repair program is available\*

Note that seal sizes 6.125" and above are supplied without a pivot ring

\*Replacement seal kits are available\*

CURC™ Size Chart (mm)

A	B	C	D	E	ØFmin	ØFmax	ØGmin	ØGmax	ØHmax	I	J
24	104.8	54.0	49.2	13.2	40.0	46.0	67.0	90.5	12.0	28.6	40.5
25	104.8	54.0	49.2	13.2	41.0	49.0	67.0	90.5	12.0	28.6	40.5
28	108.0	57.2	52.4	13.2	44.0	52.3	70.3	93.6	12.0	28.6	40.5
30	111.0	60.4	55.6	13.2	46.0	55.5	73.5	96.8	12.0	28.6	40.5
32	111.0	60.4	55.6	13.2	48.0	55.5	73.5	96.8	12.0	28.6	40.5
33	111.0	60.4	55.6	13.2	49.0	55.5	73.5	96.8	12.0	28.6	40.5
35	111.0	63.5	58.8	13.2	51.0	57.5	76.6	96.8	12.0	28.6	40.5
38	127.0	71.5	65.0	16.4	57.2	60.4	85.7	114.3	12.0	28.6	44.5
40	127.0	71.5	65.0	16.4	58.0	60.4	85.7	114.3	12.0	28.6	44.5
43	139.7	81.0	71.4	16.4	61.0	69.9	95.3	127.0	12.0	28.6	44.5
45	139.7	81.0	71.4	16.4	63.5	69.9	95.3	127.0	12.0	28.6	44.5
48	139.7	81.0	71.4	16.4	66.7	73.0	95.3	127.0	12.0	28.6	44.5
50	152.4	90.5	77.8	16.4	68.0	76.2	104.8	139.7	12.0	28.6	44.5
53	152.4	90.5	77.8	16.4	71.0	76.2	104.8	139.7	12.0	28.6	44.5
55	165.1	96.8	84.1	16.4	74.0	82.5	114.3	149.2	16.0	28.6	44.5
58	165.1	96.8	84.1	16.4	76.2	82.6	114.3	149.2	16.0	28.6	44.5
60	165.1	96.8	84.1	16.4	79.4	85.7	114.3	149.2	16.0	28.6	44.5
63	177.8	109.5	96.8	19.6	85.8	92.1	127.0	160.3	16.0	31.8	47.7
65	177.8	109.5	96.8	19.6	88.9	95.3	127.0	160.3	16.0	31.8	47.7
68	177.8	109.5	96.8	19.6	92.1	98.4	127.0	160.3	16.0	31.8	47.7
70	177.8	109.5	96.8	19.6	92.1	98.4	127.0	160.3	16.0	31.8	47.7
75	190.5	125.4	108.0	19.6	98.5	108.0	142.9	173.0	16.0	31.8	47.7
80	190.5	125.4	108.0	19.6	101.6	111.1	142.9	173.0	16.0	31.8	47.7
85	203.2	135.0	117.5	19.6	108.0	117.5	155.6	182.5	20.0	31.8	47.7
90	215.9	150.8	127.0	19.6	114.3	127.0	171.5	195.2	20.0	31.8	47.7
95	215.9	150.8	127.0	19.6	117.5	130.2	171.5	195.2	20.0	31.8	47.7
100	228.6	168.3	136.5	19.6	123.9	139.7	188.9	207.9	20.0	31.8	47.7
105	228.6	168.3	136.5	19.6	130.1	149.2	189.0	208.0	20.0	31.8	47.7
110	241.3	177.8	146.1	19.6	136.5	158.8	198.4	220.6	20.0	31.8	47.7
115	254.0	186.6	155.6	19.6	142.9	168.3	211.1	230.2	22.0	31.8	47.7
120	254.0	186.6	155.6	19.6	142.9	168.3	211.1	230.2	22.0	31.8	47.7
125	254.0	186.6	155.6	19.6	149.2	168.3	211.1	230.2	22.0	31.8	47.7

Seal sizes from 130mm to 300mm are designed to suit specific equipment using modular components. Contact AESSEAL® technical department for dimensional information and availability.

For exotic alloy versions, add 3" to seal length inboard

\*Factory repair program is available\*

Note that seal sizes 6.125" and above are supplied without a pivot ring

\*Replacement seal kits are available\*

## CRCO™ - Cartridge Single Mechanical Seal with Secondary Oil Seal

When a barrier fluid is added to a standard CURC™ gland some fluid will escape to atmosphere (past the restriction bush).

The CRCO™ option substitutes the carbon restriction bushing with an oil seal and is capable of sealing secondary fluids, at barrier pressures up to 10 psig (2/3 of a barg). This oil is an ideal barrier fluid, with a Water/Soluble oil mixture an acceptable alternative (Do not use Chrome Oxide seal faces with oil barrier fluid). Water alone does not provide sufficient lubrication for an oil seal.

The positively located centring clips on the CRCO™ (and CURC™) seal also guarantee concentricity between the cartridge seal sleeve and the gland. This positive centring assists in extending oil seal life.

The oil seal, sealing the barrier fluid, may well have a shorter life than the mechanical seal on the process liquid side. A mechanical seal would normally only be removed from service when the process fluid passes the seal faces and not when the barrier fluid oil seal fails. Where possible a fully operating double seal should be used for maximum seal life.

The major benefit of the CRCO™ option is that, by design, the CRCO™ and CURC™ option are identically priced, making a seal with a low pressure barrier fluid commercially attractive.

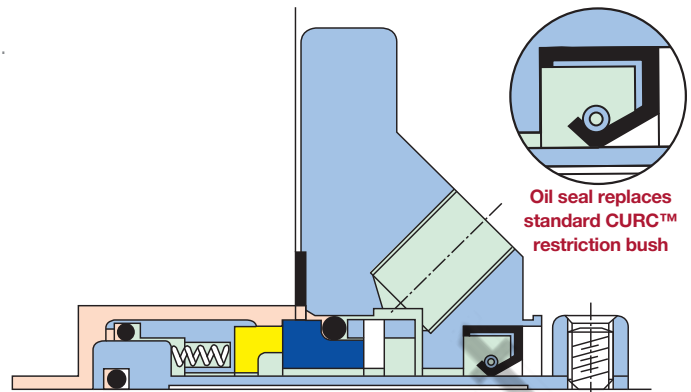

## ANSI+ CURC™ - Gland Designs to suit ANSI+ Pumps

ANSI+ Gland can be supplied for CURC™, CRCO™ and CURE™ seals.

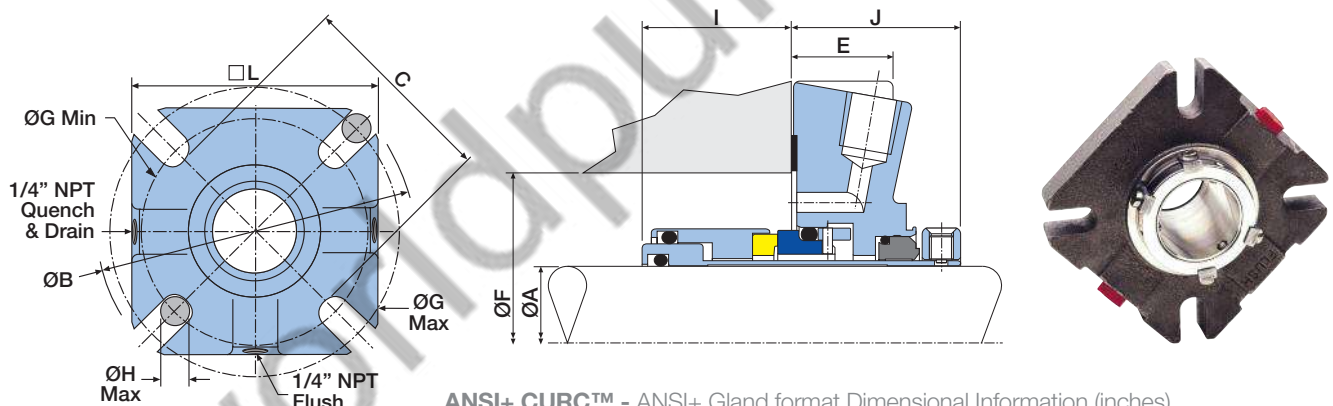

ANSI+ CURC™ - ANSI+ Gland format Dimensional Information (inches)

A	B	C	E	F min	F max	G min	G max	H max	I	J	□L
1.125	5.000	3.188	1.000	2.625	2.850	3.750	4.250	0.500	1.125	1.565	3.990
1.375	5.375	3.438	1.000	2.875	3.100	4.000	4.625	0.500	1.125	1.565	4.240
1.750	6.750	4.438	0.644	3.500	4.100	5.000	6.000	0.500	1.125	1.690	5.480
1.875	6.750	4.438	0.644	3.625	4.100	5.000	6.000	0.500	1.125	1.690	5.480
2.125	7.625	4.688	0.644	3.875	4.225	5.375	6.687	0.625	1.250	1.690	6.230
2.500	8.250	5.438	0.644	4.500	5.100	6.125	7.312	0.625	1.300	1.890	6.730
2.625	8.250	5.438	0.644	4.625	5.100	6.125	7.312	0.625	1.300	1.890	6.730
2.750	8.250	5.438	0.644	4.625	5.100	6.125	7.312	0.625	1.300	1.890	6.730

Minimum bolt circle based on bolt size shown.

## Bi-Metal CURC™ - Cartridge Single Mechanical Seal

This single cartridge seal with Exotic Alloy wetted components (coloured red) is based around the CURC™ seal design.

This seal is inventoried in ANSI sizes with Alloy 276, Alloy B-3, Titanium, Monel and Alloy 20 wetted components as standard.

The modular design enables the seal to be offered as a Bi-Metal CURE™ and CRCO™ as well.

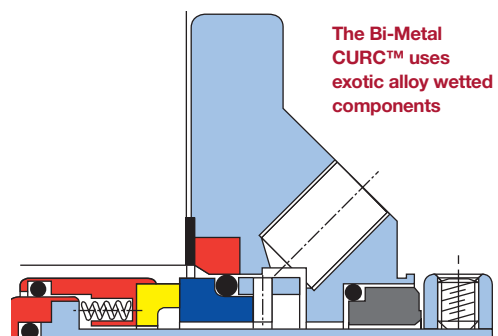

# CURE™ - Cartridge Mechanical Seal with Secondary Seal

The CURE™ mechanical seal has been designed to bridge the gap between a single and a double cartridge seal.

Traditionally this market sector is serviced by single seals using a rotary lip seal (e.g. an oil seal like the CRCO™). Such designs are capable of sealing secondary fluids, at barrier pressures up to 10 psig (2/3 of a barg), but often experience limited lip seal life. This disadvantage is overcome with the CURE™ mechanical seal which retains all the advantages of the CURC™ but incorporates a secondary seal as well.

Item	Description	Material
1	Rotary O Ring	Viton® / EPR / Kalrez® / Atlas®
2	Sleeve O Ring	Viton® / EPR / Kalrez® / Atlas®
3	Sleeve	316L Stainless Steel
4	Springs	Alloy 276
5	Rotary Drive Pins (not shown)	Stainless Steel
6	Rotary Face	316L SS - Carbon / TC / SiC*
7	Stationary Face	SiC / Ceramic** / TC / 316L SS
8	Stationary O Ring	Viton® / EPR / Kalrez® / Atlas®
9	Pivot Ring	316L Stainless Steel
10	Gland Pins (not shown)	Stainless Steel
11	Gland	316 Stainless Steel
12	External Stationary Face	Carbon
13	External Stat O Ring	Viton® / EPR
14	Clamp Ring	316L Stainless Steel
15	Drive Screws (not shown)	Stainless Steel
16	Clip Screws	Stainless Steel
17	Setting Clips	Brass
18	Anti-Tamper Screws (not shown)	Stainless Steel
19	External Rotary Face	316L SS - Cr.OX
20	External Rotary O Ring	Viton® / EPR
21	Springs	Alloy 276
22	Gasket	AF1 / GFT

\*This material is not available in some sizes above 4.000" (100mm).

ITEM 5 is an integral part of ITEM 3

\*\*Not available in all sizes - contact AESSEAL® for more information.

ITEM 10 is an integral part of ITEM 11

## Additional Barrier Fluid Information

On processes where leakage of the primary product being sealed cannot be tolerated, the barrier fluid pressure should normally be set at 15 psig (1 barg) above the stuffing box pressure and a CDSA™ double seal should be used.

Where a barrier fluid pressure between 10 psig (2/3 of a barg) and 30 psig (2 barg) is required, please contact our Technical Department. Please note however that a higher pressure version of the CURE™ will not operate effectively at zero gauge pressure, with a very low pressure less than 5 psig (1/3 of a barg), or in a vacuum. The CURE™ is available in the following sizes: Ø1.000" - 4.000" (24mm - 100mm).

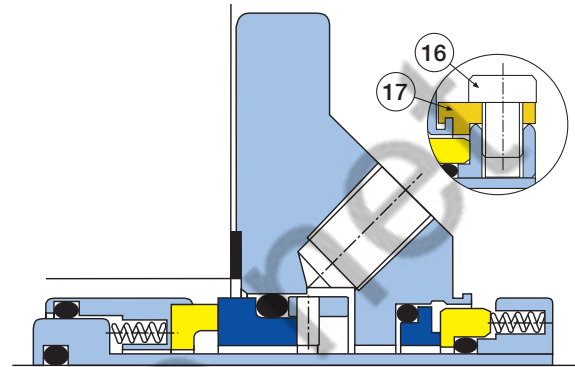

## Higher Pressure Barrier Fluid

Some modern process pumps operate in vacuum conditions or with a stuffing box pressure of less than 10 psig (2/3 of a barg). System pressure / discharge head can be considerably higher and is often a poor indicator of the actual stuffing box pressure.

Where stuffing box pressure is less than 10 psig (2/3 of a barg) the CURE™ is capable of operating at a higher barrier fluid pressure to seal abrasive media and some corrosive chemical applications.

## Lower Pressure Barrier Fluid

Even where the Stuffing Box Pressure exceeds 10 psig (2/3 of a barg) the CURE™ can extend seal life. By operating at a lower barrier fluid pressure the CURE™ cools hot liquids, lubricates the seal faces to extend "dry running" capability and also prevents the formation of abrasive crystals.

**The CURE™ Cartridge Mechanical Seal should Not be used on a vertically mounted application.**

## Environmental Control Systems for the CURE™

In addition to a vast range of mechanical seals, AESSEAL® has a specialized systems division, dedicated to the design and manufacture of a comprehensive range of seal support packages for double mechanical seals. These support systems range from Thermosyphon systems, SWFF-TF™, FLOWTRUE™ and AES-15™ to the fully featured forced circulation system PUMPPAC™ for use on oil and water applications.

### SWFF-TF™



### FLOWTRUE™



### AES-15™



### PUMPPAC™



The systems above are compatible with a wide selection of barrier and buffer fluid media. They are supplied pre-assembled with all necessary components and fittings. On site inventory costs are reduced by modular system construction.

# CDP™ and CDPN™ Cartridge Double Mechanical Seal

The CURC™ range of cartridge single mechanical seals is complemented by the CDSA™ double cartridge mechanical seal. Inventoried in sizes from 1.000" to 5.000" (24mm to 125mm) and available in sizes up to 12.000" (300mm). The standard CDSA™ incorporates self aligning faces inboard and outboard.

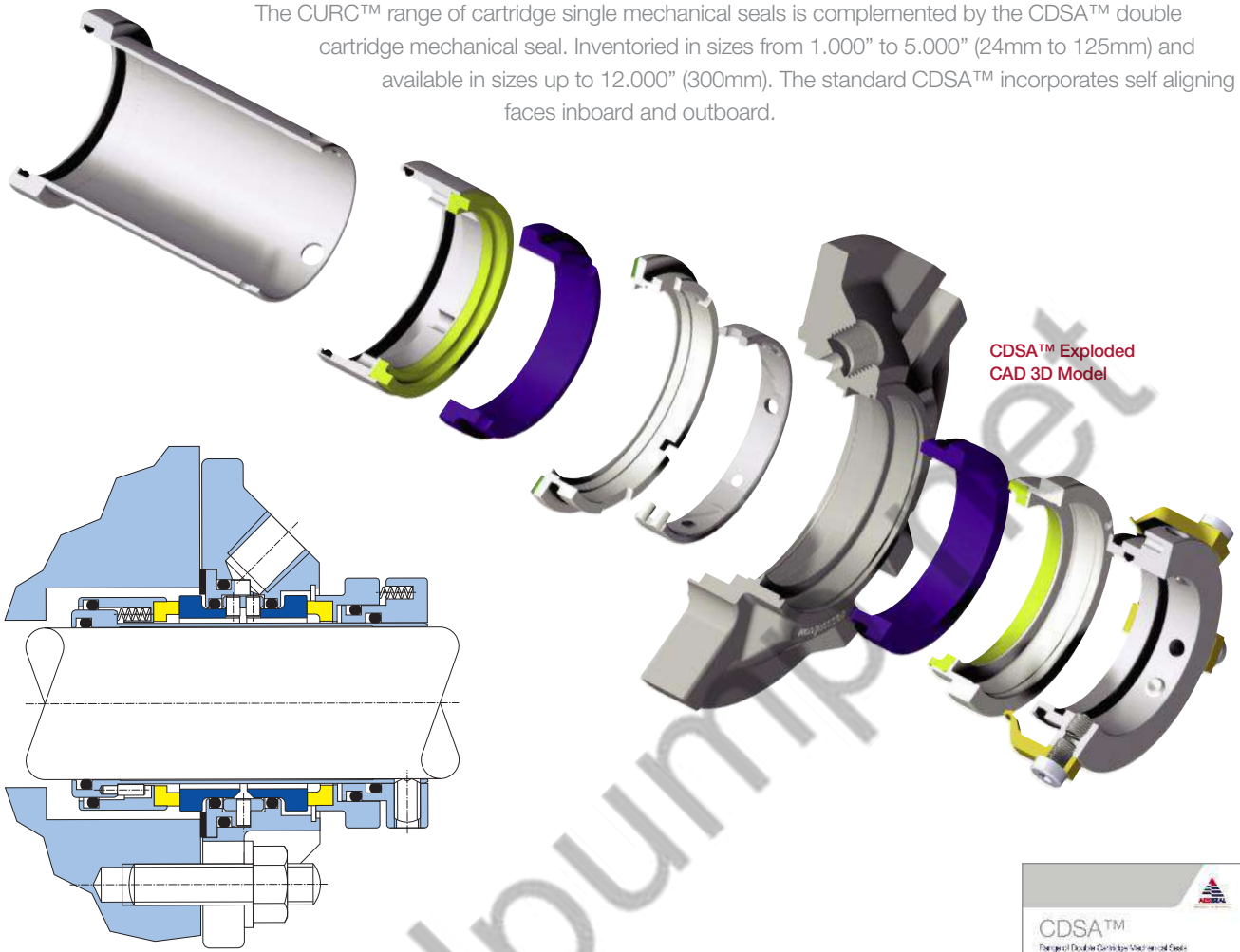

CDSA™ Exploded CAD 3D Model

The CDSA™ has double pressure balanced rotaries and independent seal face design. It is also available with double or tandem seal protection. Both CURC™ and CDSA™ products employ modular components, thereby increasing availability and reducing product lead time.

This CDSA™ brochure is available by contacting the Marketing Department at [marketing@aes seal.com](mailto:marketing@aes seal.com) or can be downloaded by visiting our website at [www.aes seal.com](http://www.aes seal.com)



This document is designed to provide dimensional information and an indication of availability. For further information and safe operating limits contact our technical specialists at the locations below.



Use double mechanical seals with hazardous products. Always take safety precautions:

**WARNING**

- Guard your equipment
- Wear protective clothing

**UK Sales & Technical advice:**  
 AESSEAL plc  
 Mill Close  
 Bradmarsh Business Park  
 Rotherham  
 S60 1BZ  
 United Kingdom

Tel: +44 (0) 1709 369966  
 Fax: +44 (0) 1709 720788  
 E-mail: [seals@aes seal.com](mailto:seals@aes seal.com)

Distributed by:

'Our purpose is to give our customers such exceptional service that they need never consider alternative sources of supply.'

[www.aes seal.com](http://www.aes seal.com)

**USA Sales & Technical advice:**  
 AESSEAL Inc.  
 355 Dunavant Drive  
 Rockford  
 TN. 37853  
 USA

Tel: +1 865 531 0192  
 Fax: +1 865 531 0571  
 E-mail: [usa@aes seal.com](mailto:usa@aes seal.com)

**Important:** Since the conditions and methods of use of this product are beyond our control, AESSEAL plc expressly disclaims any and all liability resulting or arising from any use of this product or reliance on any information contained in this document - AESSEAL plc standard conditions of sale apply. All sizes are subject to manufacturing tolerances. We reserve the right to modify specifications at any time. AESSEAL® is a Registered Trademark of AESSEAL plc, AESSEAL plc recognizes all trademarks and trademark names as the property of their owners.