

CLIP™

Cartridge Lip Seal



- Dry running cartridge seal
- Supplied with quench and drain environmental ports
- Externally mounted

CLIP™ - Cartridge Lip Seal Design

The AESSEAL® CLIP™ seal is specifically designed for dry running applications where barrier fluid is not permitted to enter the process media.

This makes the design ideally suited for slow rotating equipment in the food and pharmaceutical industries. Typical applications include the Viking Universal, 124-125 and 4124-4125 pump ranges. The seal design uses the latest monolithic graphite impregnated PTFE lip seal technology. This reduces lip seal wear and debris, thereby helping to increase seal life.

Other design features include:

- Hard plated cartridge sleeve extends lip seal life
- Factory assembled and tested
- Replaceable cartridge sleeve eliminates shaft wear
- Ease of lip seal repair. The monolithic lip seal unit eliminates separate lip seal rings and spacers

Dry Running Performance

The seal design is offered for shaft speeds up to 3.3 m/s (650ft/min).

Lubricated Fluid Running Performance

The seal design is offered for shaft speeds up to 9.6 m/s (1,900ft/min) under **true** lubricated conditions. Please consult AESSEAL® Technical Department for applications which exceed these shaft speeds.

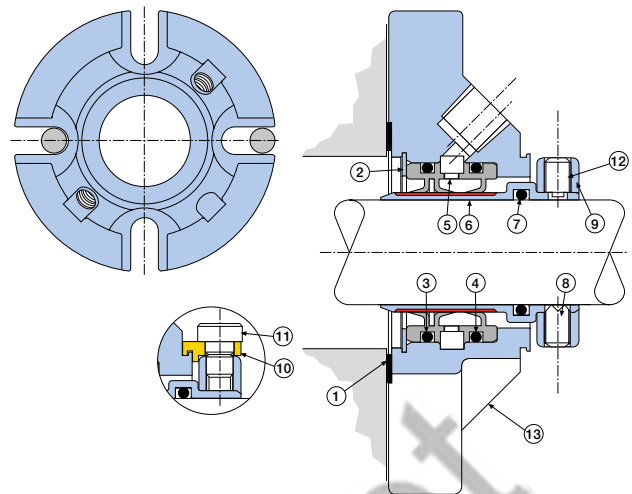

CLIP Seal Labeling

Item	Description	Material
1	Gasket	AF1 / GFT
2	Circlip	Stainless Steel
3	O Ring	FKM / EPR / FFKM / TFE/P
4	O Ring	FKM / EPR / FFKM / TFE/P
5	Lipseal	Graphite PTFE
6	Sleeve	316L Stainless Steel - Cr.Ox.
7	O Ring	FKM / EPR / FFKM / TFE/P
8	Drive Screws	Stainless Steel
9	Clamp Ring	316L Stainless Steel
10	Setting Clips	Brass
11	Clip Screws	Stainless Steel
12	Anti Tamper Screws	Stainless Steel
13	Gland	316 Stainless Steel

CLIP Seal Dimensional Information (Inches)

Seal Size	ØA	ØB	C	D	E	ØF Max	ØG Min	ØG Max	H	I	J	K
1.437	1.437	4.000	2.870	n/a	1.055	2.312	3.375	3.562	0.438	0.120	1.625	0.570
1.500	1.500	4.990	2.812	2.562	0.644	2.375	3.375	4.437	0.500	0.050	1.710	0.933
1.625	1.625	4.990	2.812	2.562	0.644	2.500	3.375	4.437	0.500	0.050	1.710	0.933
2.437	2.437	6.687	4.312	3.812	0.769	3.625	5.000	6.062	0.625	0.060	1.875	1.129
2.500	2.500	6.990	4.312	3.812	0.769	3.625	5.000	6.312	0.625	0.060	1.875	1.129

Complementary Gas Panel Seal Support Systems

To complement the dry running capability of the CLIP™ seal design, AESSEAL® offer a modular range of Gas Panel Seal Support Systems (Figure 1). These Gas Panels have a number of features to ensure a consistent and controlled flow of pressurised gas barrier to the mechanical seal faces.



Figure 1

Please contact your local AESSEAL® representative to discover more about the Gas Panel Systems.

This brochure is fully recyclable. When laminated, a sustainable, biodegradable and recyclable lamination is used.

For further information and safe operating limits contact our technical specialists at the locations below.



Use double mechanical seals with hazardous products.

Always take safety precautions:

WARNING

- Guard your equipment
- Wear protective clothing

AESSEAL plc is certified to ISO 9001, ISO 14001, ISO/IEC 20000, ISO/IEC 27001, ISO/TS 29001, ISO 37001, ISO 45001 & ISO 50001

UK Sales & Technical advice:

AESSEAL plc
Mill Close
Bradmarsh Business Park
Rotherham,
S60 1BZ, UK

Tel: +44 (0) 1709 369966

E-mail: enquiries@aes seal.info

www.aes seal.com



AESSEAL plc is Net Zero for Manufacturing in the UK



USA Sales & Technical advice:

AESSEAL Inc.
355 Dunavant Drive
Rockford,
TN. 37853,
USA

Tel: +1 865 531 0192

E-mail: usa@aes seal.com

www.aes seal.com

Important: Since the conditions and methods of use of this product are beyond our control, AESSEAL plc expressly disclaims any and all liability resulting or arising from any use of this product or reliance on any information contained in this document - AESSEAL plc standard conditions of sale apply. All sizes are subject to manufacturing tolerances. We reserve the right to modify specifications at any time. AESSEAL® is a Registered Trademark of AES Engineering Ltd, AESSEAL plc recognizes all trademarks and trademark names as the property of their owners.