



## CDFI™ / CDFC™ Cartridge Double Flow Induction/Convection



- PATENT PENDING DESIGN
- INTEGRAL BI-DIRECTIONAL FLOW INDUCER
- DIRECTED BARRIER FLUID CIRCULATION
- FITS ON PUMPS WITH THIN RADIAL CROSS SECTIONAL SPACES

## CDFI™ / CDFC™ - better by design

The AESSEAL® CDFI™ / CDFC™ is an innovative modular adaptation of the BDFI™ / BDFC™.

The CDFI™ / CDFC™ bridges the product range gap between the CDSA™ and DMSF™ differentiating itself in two areas. The hybrid design offers a metal-to-metal inboard drive and an integral bi-directional pumping device, allowing the seal to fit in radial cross sectional spaces as small as 0.312" (8mm).

The CDFI™ / CDFC™ is available in any AESSEAL® standard seal face and elastomer combination.

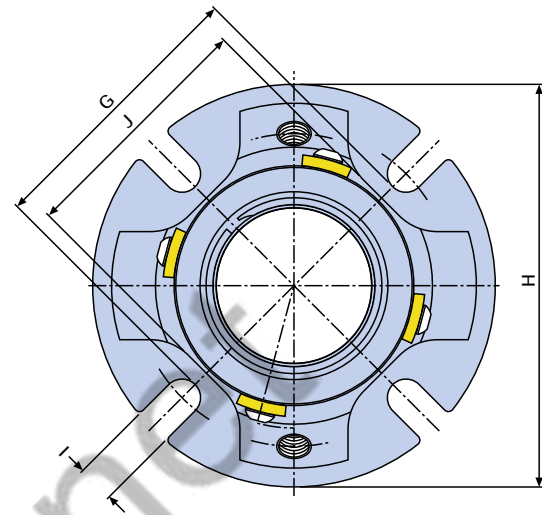

### Directed Barrier Fluid Circulation

Removing the heat at the inboard faces is critical for any double mechanical seal.

The CDFI™ / CDFC™ directed barrier fluid flow path achieves effective heat removal at both sets of seal faces.

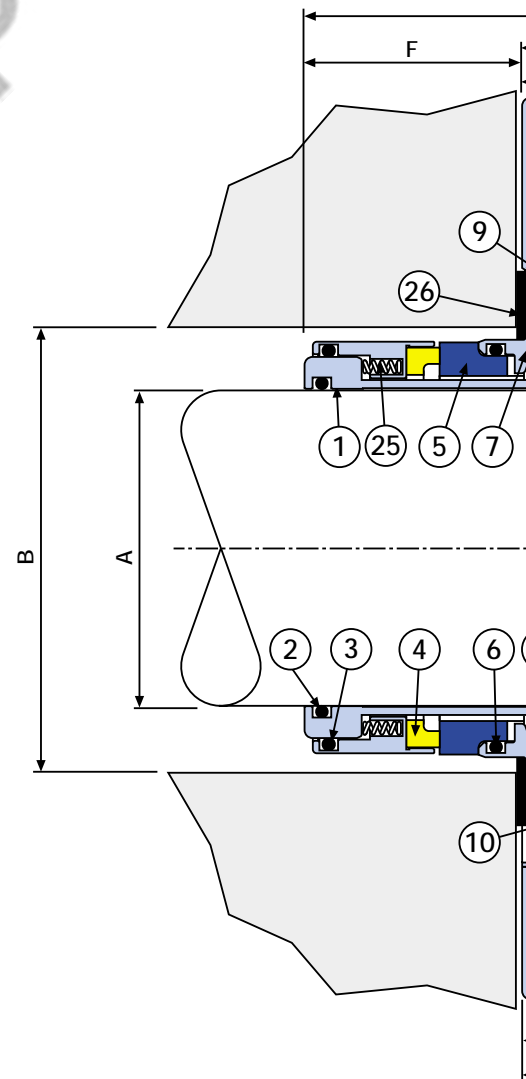
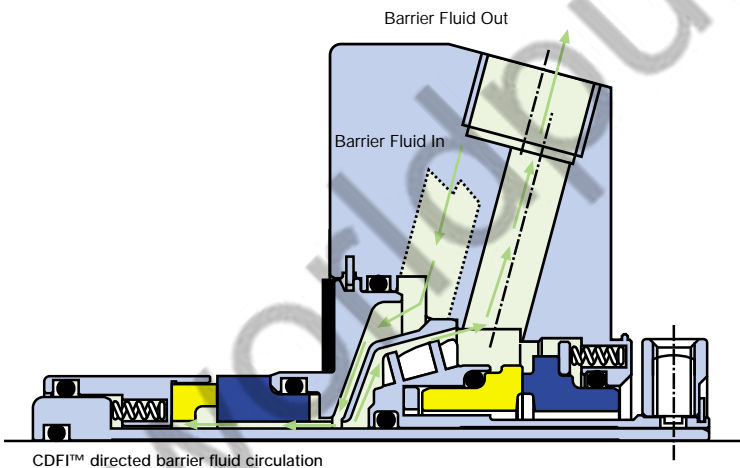

### Bi-directional Barrier Fluid Circulation

Developed using the highly efficient Patent Pending DMSF™ pumping ring the CDFI™ will effectively and reliably circulate barrier fluid irrespective of the direction of shaft rotation.

Alternatively, in applications which use an external barrier fluid circulation device, such as a Pumppac™, or where fluid convection is required, the CDFC™ may be offered.

### Fits in Thin Radial Cross Sectional Spaces

Like the CDSA™, the CDFI™ / CDFC™ can be installed on equipment with radial cross sectional spaces as small as 0.312" (8mm). This is typical on some smaller sized process pumps.

Standard ISO / ANSI Box Bore 28.0mm - 65mm (1.125" - 2.625")

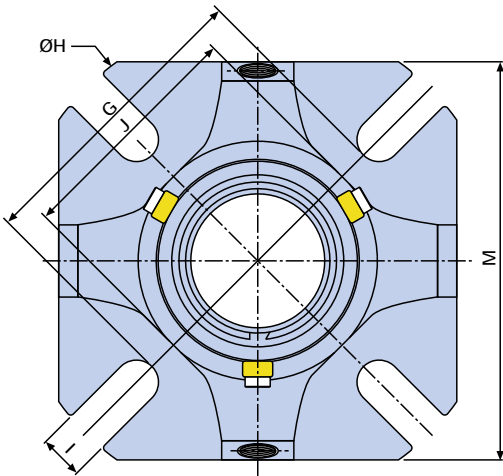

A	B Min	B Max	C	D	E	F	G	H	I	J	K	L
28.0	44.0	52.0	19.1	90.0	52.4	37.6	62.2	111.1	14.0	57.2	20.6	28.6
35.0	51.0	60.3	19.1	90.0	52.4	37.6	71.8	104.1	11.0	67.0	20.6	28.6
45.0	63.5	73.0	19.1	92.8	53.1	39.7	83.8	139.1	14.0	75.7	31.5	33.0
55.0	74.0	90.5	22.2	94.4	53.1	41.3	100.3	150.0	17.5	86.6	25.3	29.0
60.0	79.4	95.0	19.1	94.4	53.1	41.3	108.7	170.8	17.5	94.4	26.5	29.7
63.0	85.8	95.0	19.1	95.5	53.1	42.4	108.7	170.8	17.5	94.4	31.5	33.0
65.0	88.9	98.0	19.1	95.5	53.1	42.4	111.9	180.3	17.5	98.3	31.5	33.0
1.125	1.750	2.062	0.750	3.546	2.062	1.484	2.449	4.375	0.551	2.250	0.812	1.125
1.375	2.000	2.375	0.750	3.546	2.062	1.484	2.827	4.100	0.433	2.638	0.812	1.125
1.750	2.500	2.875	0.750	3.653	2.091	1.562	3.297	5.475	0.551	2.982	1.240	1.299
1.875	2.625	3.000	0.750	3.653	2.091	1.562	3.450	5.906	0.689	3.108	1.240	1.299
1.875-D	2.625	2.875	0.800	3.653	2.091	1.562	3.325	4.875	0.472	3.025	1.150	1.150
2.125	2.875	3.562	0.875	3.716	2.091	1.625	3.950	5.906	0.689	3.408	0.995	1.140
2.375	3.125	3.750	0.750	3.716	2.091	1.625	4.280	6.725	0.689	3.716	1.043	1.170
2.500	3.375	3.750	0.750	3.761	2.091	1.670	4.280	6.725	0.689	3.716	1.240	1.299
2.625	3.500	3.875	0.750	3.761	2.091	1.670	4.405	7.100	0.689	3.871	1.240	1.299

Standard ISO / ANSI Box Bore 75.0mm - 100mm (2.750" - 4.000")

A	B Min	B Max	C	D	E	F	G	H	I	J	K	L
75.0	98.5	117.4	23.8	106	63.5	42.5	131.4	189.2	17.5	116.5	36.0	40.1
80.0	101.6	127.0	23.8	106	63.5	42.5	142.5	201.9	21.0	126.0	36.0	40.1
85.0	108.0	127.0	23.8	106	63.5	42.5	142.5	201.9	21.0	126.0	36.0	40.1
90.0	114.3	136.5	23.8	106	63.5	42.5	152.0	214.6	21.0	135.5	36.0	40.1
95.0	117.5	139.7	23.8	106	63.5	42.5	155.2	227.3	21.0	138.7	36.0	40.1
100.0	123.9	152.4	23.8	106	63.5	42.5	167.9	240.0	21.0	151.4	36.0	40.1
2.750	3.625	4.625	0.937	4.170	2.500	1.670	5.173	7.450	0.689	4.585	1.418	1.578
2.875	3.750	4.625	0.937	4.170	2.500	1.670	5.173	7.450	0.689	4.585	1.418	1.578
3.000	3.875	4.625	0.937	4.170	2.500	1.670	5.173	7.450	0.689	4.585	1.418	1.578
3.125	4.000	5.000	0.937	4.170	2.500	1.670	5.610	7.950	0.827	4.960	1.418	1.578
3.250	4.125	5.000	0.937	4.170	2.500	1.670	5.610	7.950	0.827	4.960	1.418	1.578
3.375	4.250	5.000	0.937	4.170	2.500	1.670	5.610	7.950	0.827	4.960	1.418	1.578
3.500	4.375	5.375	0.937	4.170	2.500	1.670	5.985	8.450	0.827	5.335	1.418	1.578
3.625	4.500	5.375	0.937	4.170	2.500	1.670	5.985	8.450	0.827	5.335	1.418	1.578
3.750	4.625	5.500	0.937	4.170	2.500	1.670	6.110	8.950	0.827	5.460	1.418	1.578
3.875	4.750	5.500	0.937	4.170	2.500	1.670	6.110	8.950	0.827	5.460	1.418	1.578
4.000	4.875	6.000	0.937	4.170	2.500	1.670	6.610	9.450	0.827	5.960	1.418	1.578

Large ISO / ANSI Plus Box Bore

A	B Min	B Max	C	D	E	F	G	H	I	J	K	L	M
1.125	1.750	2.750	0.750	3.546	2.062	1.484	3.199	5.000	0.551	2.323	1.125	1.125	3.990
1.375	2.000	3.062	0.750	3.546	2.062	1.484	3.449	5.375	0.551	2.638	1.125	1.125	4.250
1.750	2.625	4.000	0.790	3.653	2.000	1.653	4.449	6.750	0.551	3.100	1.087	1.087	5.480
1.875	2.625	4.000	0.619	3.653	2.000	1.653	4.449	6.750	0.551	3.500	1.087	1.087	5.480
2.125	2.875	4.187	0.669	3.716	2.000	1.716	4.661	7.600	0.689	3.715	1.125	1.125	6.205
2.500	3.500	4.812	0.760	3.761	2.091	1.670	5.411	8.225	0.689	4.525	1.231	1.231	6.705
2.625	3.500	4.812	0.760	3.761	2.091	1.670	5.411	8.225	0.689	4.525	1.093	1.093	6.705

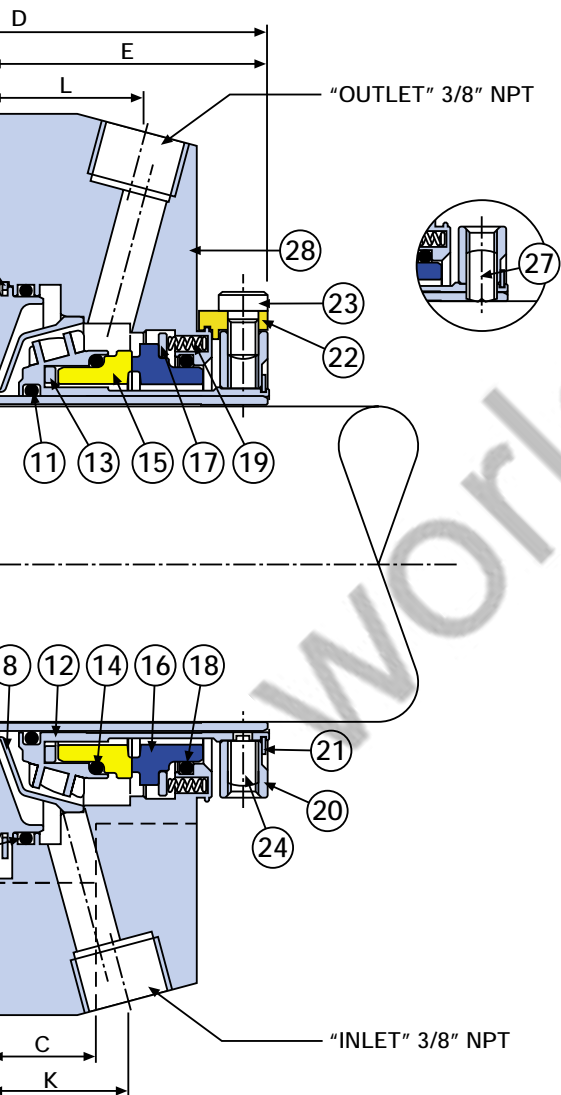

Item	Description	Material
1	Sleeve	316L SS
2	Sleeve O Ring	Viton® / EPR / Kalrez® / Alfas®
3	Rotary O Ring	Viton® / EPR / Kalrez® / Alfas®
4	Rotary Face	316L SS - Carbon / TC / SiC / Ant Car
5	Stationary Face	316L SS-CrOx / SiC / TC / Ceramic
6	Stationary O Ring	Viton® / EPR / Kalrez® / Alfas®
7	Gland Insert	316L Stainless Steel
8	Deflector	316L Stainless Steel
9	Snap Ring	Stainless Steel
10	Gland Insert O Ring	Viton® / EPR / Kalrez® / Alfas®
11	Rotary Holder O Ring	Viton® / EPR / Kalrez® / Alfas®
12	Rotary Holder	316 Stainless Steel
13	Drive Ring	316L Stainless Steel
14	Rotary O Ring	Viton® / EPR / Kalrez® / Alfas®
15	Rotary Face	SiC / TC
16	Stationary Face	Carbon / SiC / TC / Ant Car
17	Spring Plate	316L Stainless Steel
18	Stationary O Ring	Viton® / EPR / Kalrez® / Alfas®
19	Springs	Alloy 276
20	Clamp Ring	316L Stainless Steel
21	Circlip	Stainless Steel
22	Settings Clips	Brass
23	Setting Clip Screws	Stainless Steel
24	Anti Tamper Screws	Stainless Steel
25	Springs	Alloy 276
26	Gasket	AF1 / GFT
27	Drive Screws	Stainless Steel
28	Gland	316 Stainless Steel

**Important** - some glands are manufactured from castings and therefore the angle and position of the port should be checked. If in doubt, please contact the AESSEAL® Technical Department.

Contact AESSEAL® Technical Department for dimensional information of seal sizes not shown.

**Check availability as only a limited size range is inventoried.**

# CDFI™ / BDFI™ - modularity at its best

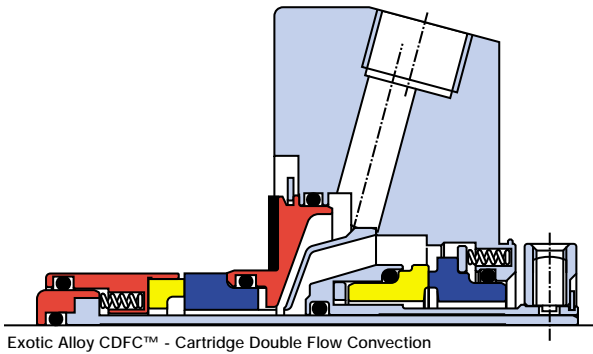

Exotic Alloy CDFC™ - Cartridge Double Flow Convection

## Exotic alloy wetted options.

The CDFI™ / CDFC™ is available in a wide range of exotic alloy wetted materials including Alloy 276, Alloy 20, Titanium, Alloy 400 and Alloy 255.

The design utilizes the modular Patented Bi-Metal design of the exotic CDSA™.

Like all AESSEAL® products, modularity is key to providing service at an affordable price.

EXOTIC ALLOY SEALS  
Contact AESSEAL® for availability of Exotic Alloy options.

The BDFI™ and BDFC™ are sister products to the CDFI™ and CDFC™.

The BDFI™ / BDFC™ offer the advantage of an inboard metal bellows unit available in any AESSEAL® standard metal bellows material and seal face combination including SHS, HHH and SAC with Carbon, Antimony Carbon, TC or SiC seal faces.

This inboard bellows design is ideal to replace the semi-dynamic rotary elastomer in some chemical or thermal applications

See the BDFI™ / BDFC™ literature for further information. You can download this and other information from [www.aesseal.com](http://www.aesseal.com) or request it from [marketing@aes seal.com](mailto:marketing@aes seal.com)

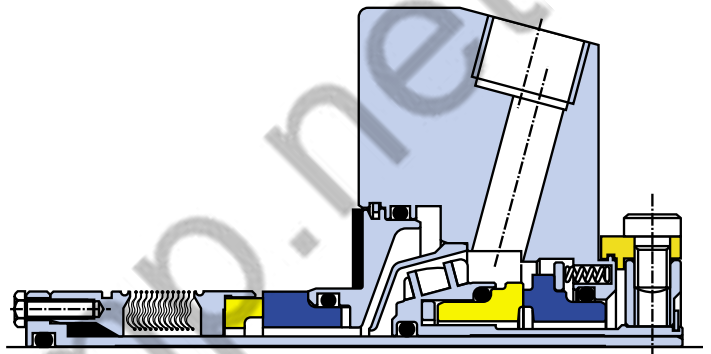

BDFI™ - Bellows Double Flow Induced

In addition to a vast range of mechanical seals, AESSEAL® has a specialized systems division, dedicated to the design and manufacture of a comprehensive range of seal support packages for double mechanical seals. These range from the SSE10™ vessel to the fully featured SD™ and PUMPPAC™ forced circulation systems.

### SSE10™



### AS15™



### SD™



### PUMPPAC™



## Environmental Control System Range

The systems above are compatible with a wide selection of Barrier and Buffer fluid mediums. They are supplied pre-assembled with all necessary components and fittings. On site inventory costs are reduced by modular system construction.

THIS DOCUMENT IS DESIGNED TO PROVIDE DIMENSIONAL INFORMATION AND AN INDICATION OF AVAILABILITY. FOR FURTHER INFORMATION AND SAFE OPERATING LIMITS CONTACT OUR TECHNICAL SPECIALISTS AT THE LOCATIONS BELOW.



INVESTOR IN PEOPLE

USE DOUBLE MECHANICAL SEALS WITH HAZARDOUS PRODUCTS. ALWAYS TAKE SAFETY PRECAUTIONS:

- GUARD YOUR EQUIPMENT
- WEAR PROTECTIVE CLOTHING



WARNING

AESSEAL plc  
Mill Close  
Templeborough  
Rotherham  
S60 1BZ  
United Kingdom

Telephone:  
Fax:  
E-mail:  
Internet:

Copyright © AESSEAL plc 2002

WINNER OF THE  
NATWEST  
SUNDAY TIMES  
COMPANY OF  
TOMORROW  
AWARD

+44 (0) 1709 369966  
+44 (0) 1709 720788  
[seals@aes seal.com](mailto:seals@aes seal.com)  
<http://www.aes seal.com>

Distributed by:

USA Sales & Technical advice:  
AESSEAL Inc.  
10231 Cogdill Road  
Suite 105  
Knoxville, TN 37932  
USA

Telephone: 865 531 0192  
Fax: 865 531 0571

ALL SIZES ARE SUBJECT TO MANUFACTURING TOLERANCES. WE RESERVE THE RIGHT TO MODIFY SPECIFICATIONS AT ANY TIME.